

RMC110

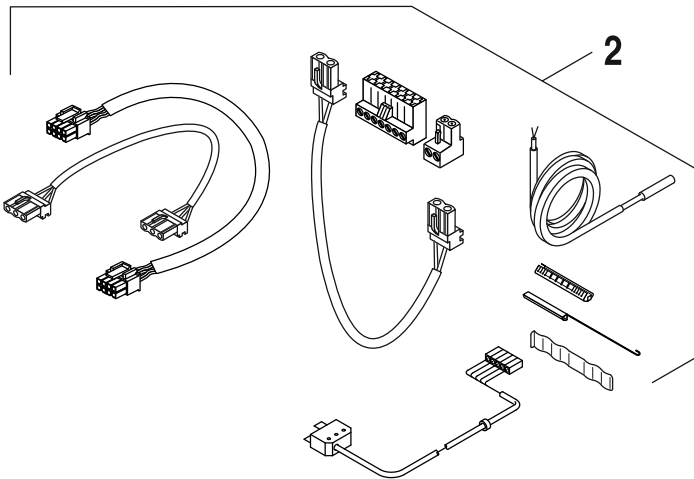
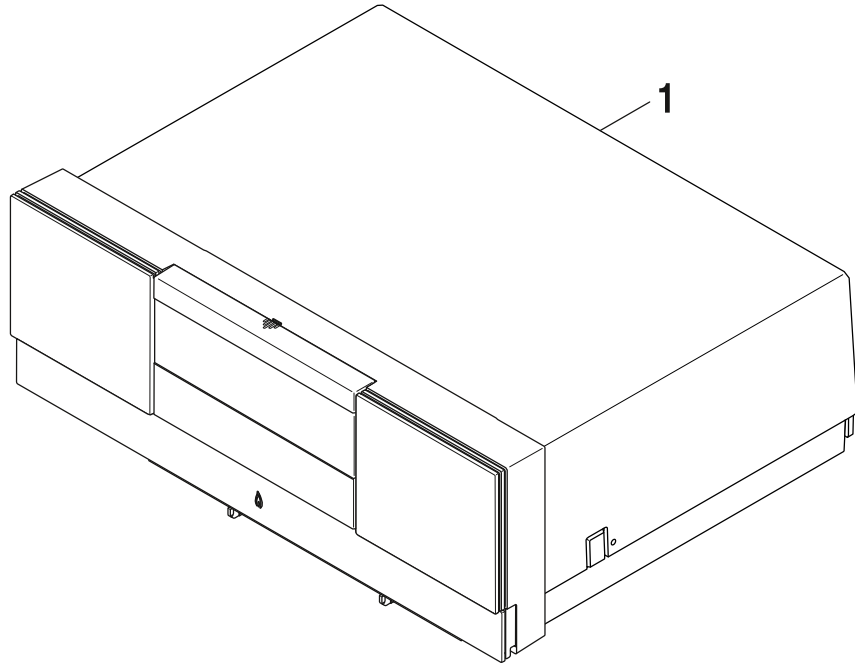

8738894099.ac.RO

[de] Wichtige Hinweise zur Installation/Montage

Die Installation/Montage muss durch eine für die Arbeiten zugelassene Fachkraft unter Beachtung der geltenden Vorschriften erfolgen.

[en] Important notes on installation/assembly

The installation/assembly must be carried out by a qualified contractor, following these instructions and in compliance with the applicable regulations.

[fr] Instructions importantes pour l'installation/le montage

L'installation/le montage doit être effectué(e) par un spécialiste qualifié pour les opérations concernées et dans le respect de la présente notice et des prescriptions applicables.

[bg] Важни указания във връзка с инсталацията/монтажа

Инсталацията/монтажът трябва да се извършва от лицензиран за работите специалист в съответствие с настоящото ръководство и с приложимите разпоредби.

[cs] Důležité pokyny k instalaci/montáži

Instalaci/montáž musí při dodržení pokynů uvedených v tomto návodu a platných předpisů provést odborný pracovník s příslušným oprávněním pro tyto práce.

[da] Vigtige anvisninger til installationen/monteringen

Installationen/monteringen skal foretages af en godkendt installatør under overholdelse af denne vejledning og de gældende forskrifter.

[el] Σημαντικές υποδείξεις για την εγκατάσταση/συναρμολόγηση

Η εγκατάσταση/τοποθέτηση πρέπει να ανατίθεται σε εκπαιδευμένο για τις συγκεκριμένες εργασίες τεχνικό προσωπικό με τήρηση αυτών των οδηγιών καθώς και των σχετικών προδιαγραφών.

[es] Indicaciones importantes para instalación/montaje

La instalación/el montaje debe realizarla personal especializado que esté autorizado para realizar estos trabajos y que tenga en cuenta estas instrucciones y la normativa vigente.

[et] Olulised juhised paigaldamiseks/montaažiks

Paigaldamist/montaaži tohib läbi viia vaid selleks volitusi omav spetsialist, arvestades kehtivaid nõudeid.

[nl-BE] Belangrijke aanwijzingen betreffende de installatie/montage

De installatie/montage moet worden uitgevoerd door een voor de werkzaamheden geautoriseerde installateur rekening houdend met deze handleiding en de geldende voorschriften.

[fi] Tärkeitä asennus- ja kokoonpano-ohjeita

Näihin töihin hyväksytyin ammattiasentajan pitää suorittaa asennus- ja kokoonpanotyöt voimassa olevien määräysten mukaisesti.

[hu] Fontos tudnivalók az installáláshoz/szereléshez

A telepítést/szerelést egy, a munkálatokra felhatalmazott szakembernek kell végeznie, jelen utasítás és az érvényes előírások figyelembevételével.

[it] Avvertenze importanti per l'installazione/il montaggio

L'installazione/il montaggio deve aver luogo ad opera di una ditta specializzata ed autorizzata in osservanza di queste istruzioni e delle direttive vigenti.

[ka] მნიშვნელოვანი მითითებები ინსტალაციისთვის/მონტაჟისთვის

ინსტალაცია/მონტაჟი უნდა განხორციელდეს საშუალებისთვის დამკვეთი კვალიფიციური პერსონალის მიერ, მოქმედი განაწესის დაცვით.

[lt] Svarbios instaliavimo ir (arba) montavimo nuorodos

Instaliavimo / montavimo darbus, laikydamiesi šios instrukcijos reikalavimų ir galiojančių taisyklių, privalo atlikti šioms darbams įgalioti specialistai.

[lv] Svarīgi norādījumi par iekārtas uzstādīšanu / montāžu

Uzstādīšanu/montāžu jāveic atbilstošajiem darbiem sertificētam speciālistam, ievērojot šo instrukciju un spēkā esošos noteikumus.

[nl] Belangrijke aanwijzingen betreffende de installatie/montage

De installatie/montage moet door een erkend installateur volgens de geldende voorschriften worden uitgevoerd.

[no] Viktig informasjon om installasjon/montering

Installasjonen/monteringen skal gjennomføres av autoriserte installatører, og installasjonsanvisningen samt gjeldende forskrifter skal følges.

[pl] Ważne wskazówki dotyczące instalacji/montażu

Instalację/montaż powinien wykonać specjalista uprawniony do tego typu prac z uwzględnieniem informacji podanych w niniejszej instrukcji oraz aktualnie obowiązujących przepisów.

[pt] Indicações importantes relativas à instalação/montagem

A instalação/montagem deve ser efectuada por um técnico autorizado para os trabalhos, respeitando este manual e as prescrições válidas.

[ro] Indicații importante privind instalarea/montajul

Instalarea/montajul trebuie realizate de către un specialist autorizat pentru lucrările respective, respectându-se prezentele instrucțiuni și prescripțiile valabile.

[ru] Важные указания по подключению/монтажу

Подключение/монтаж должны выполнять только специалисты, имеющие допуск к выполнению таких работ, при соблюдении требований этой инструкции и действующих норм и правил.

[sk] Dôležité pokyny týkajúce sa inštalácie/montáže

Inštaláciu/montáž musí vykonať odborný personál, ktorý má oprávnenie pre výkon týchto prác, pričom musí dodržiavať pokyny uvedené v tomto návode a platné predpisy.

[sl] Pomembni napotki za namestitvev/montažo

Inštalacijo/montažo lahko izvede samo pooblaščen strokovnjak ob upoštevanju teh navodil in veljavnih predpisov.

[sr] Važna uputstva za ugradnju i montažu

Ovu instalaciju/montažu moraju da obavie stručna lica koja su ovlašćena za obavljanje takvih radova u skladu sa ovim uputstvom i važećim propisima.

[sv] Viktiga anvisningar för installation/montering

Installationen/monteringen måste utföras av en behörig och tekniskt utbildad person enligt denna anvisning samt gällande föreskrifter.

[tr] Kurulum/Montaj ile ilgili önemli uyarılar

Kurulum/montaj, bu çalışmalarını yapmasına müsaade edilen uzman kişiler tarafından işbu kılavuz ve geçerli yönetmelikler dikkate alınarak yapılmalıdır.

[uk] Важливі вказівки щодо установки/монтажу

Встановлення/монтаж повинні виконувати фахівці, що допущені до виконання таких робіт, із дотриманням цієї інструкції та діючих приписів.

[zh] 安装方面的重要提示

安装和组装工作必须由经过许可的专业人员进行，同时必须遵守本说明书和现行法规的相关要求

[ar] ملاحظات هامة للتركيب/التجميع
يجب أن يتم التركيب/التجميع من قبل متخصص مصرح له بالعمل، مع مراعاة اللوائح السارية.

[fa] تذکرات مهم درباره نصب/مونتاژ
نصب/مونتاژ باید توسط فردی حرفه ای که مجاز به انجام این کار است، و همچنین با توجه کامل به مقررات مربوطه انجام شود.

[az] Quraşdırılma

Quraşdırılma işinin yerinə yetirilməsi səlahiyyətli bir mütəxəssis tərəfindən və müvafiq qaydalara uyğun olaraq aparılmalıdır.

Ersatzteilliste
Spare parts list

Liste des pièces de rechange
Lista parti di ricambio

Lista de repuestos
Yedek Parça Listesi

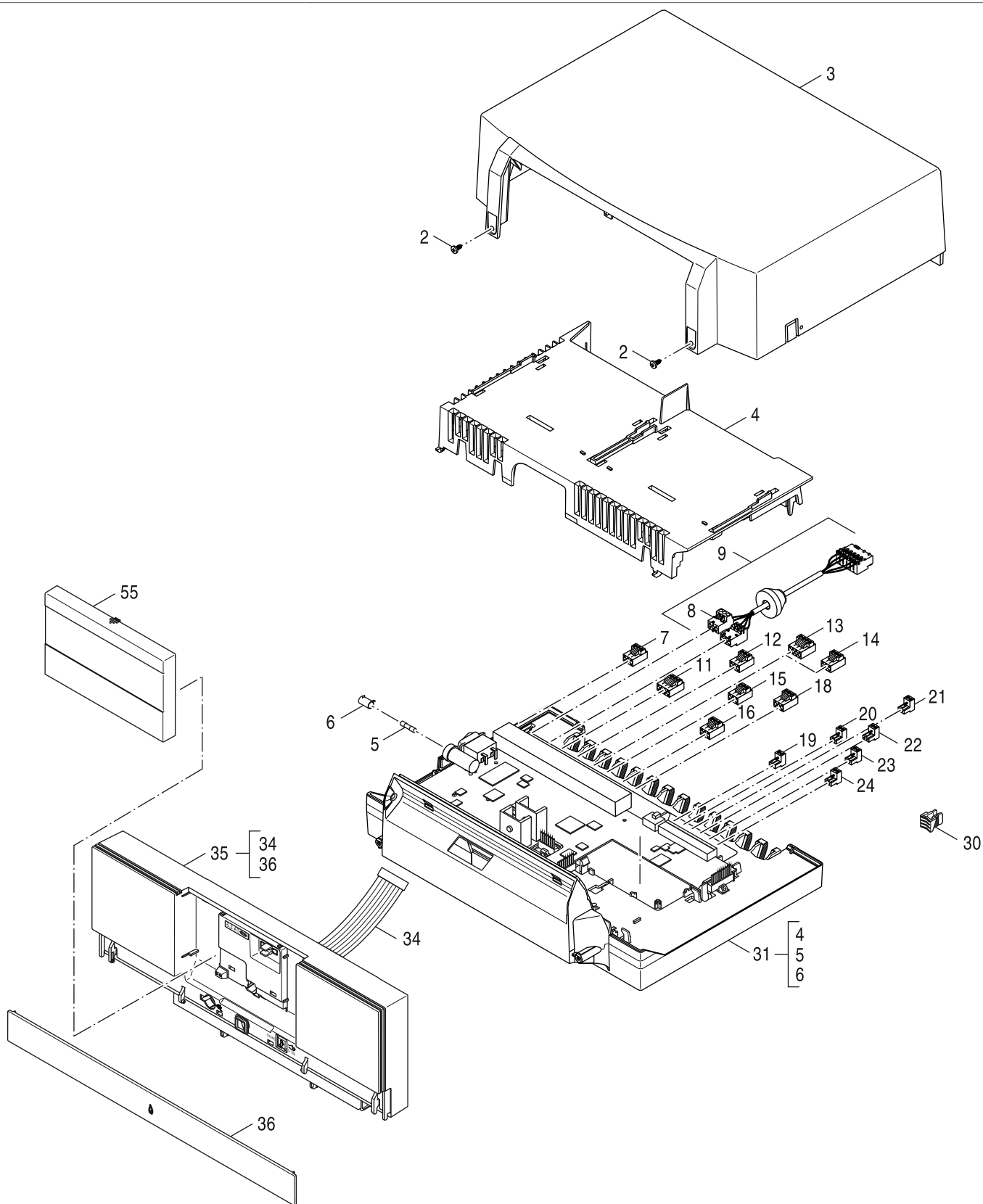

6721904597.aa.RO

1

RMC110
RMC110
RMC110
RMC110
RMC110

RMC110

Ersatzteilliste
Spare parts list

Liste des pièces de rechange
Lista parti di ricambio

Lista de repuestos
Yedek Parça Listesi

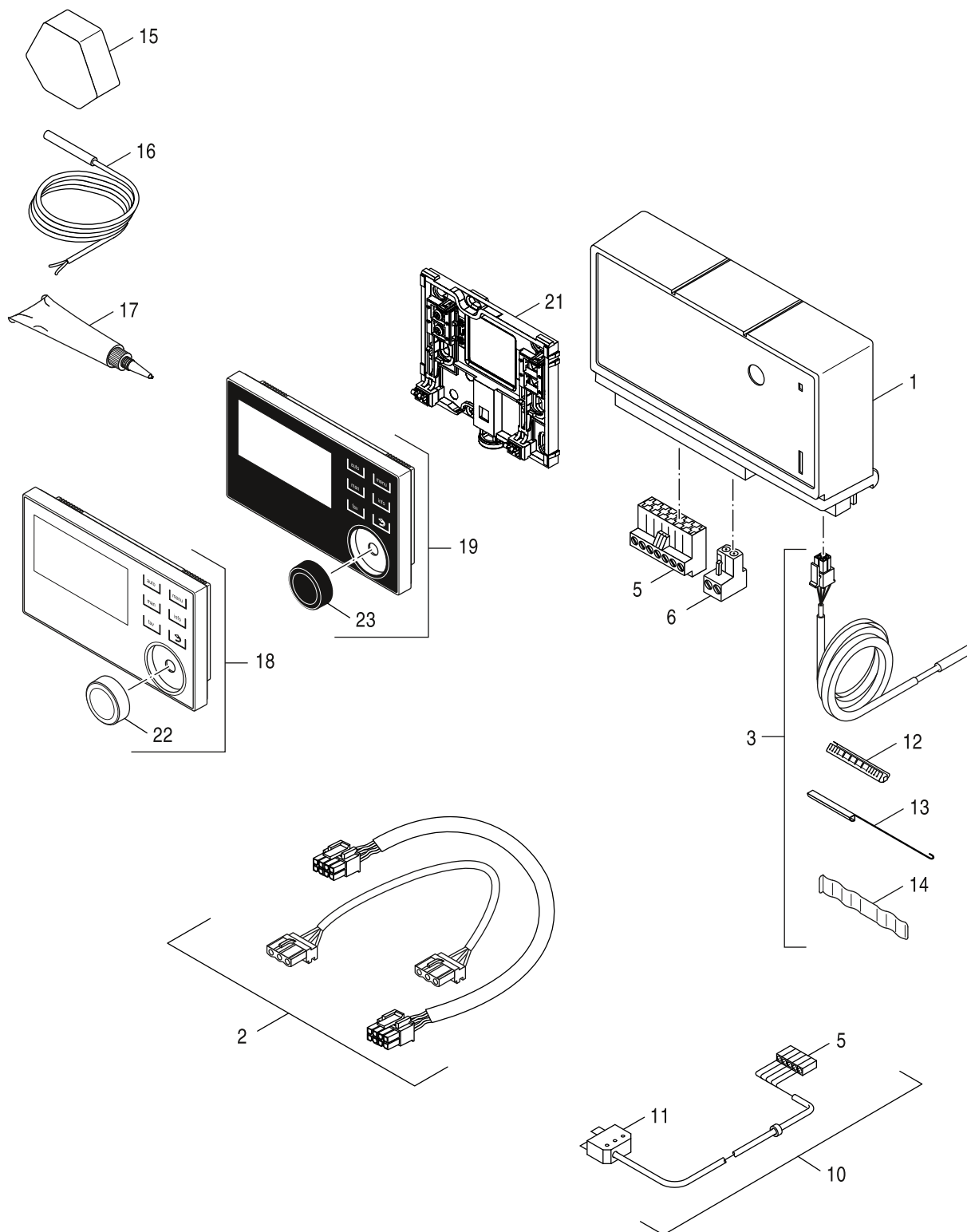

8738894538.ag.RO

2

Zubehör, Umbaueset
Accessories, Conversion set
Accessoire, Kit de transformation
Accessori, Kit di conversione
Accesorios, Kit de transformación
Aksesuar, Dönüşüm Seti

RMC110

Pos	Bezeichnung Description Dénomination Descrizioni Descripción Acıklamalar	Bestell-Nr. Ordering no. Numéro de commande N° d'ordine Número el ordenar Ordering no.	blau	blau AT,DE,LU	blue BY/KZ/RU	blue CZ	blue GR	blue PL	blue RO	blue RU/BY/UA/Baltic	blue SK	blue TR							Bemerkungen Remarks Remarques Osservazioni Observaciones Notlar
1	Modul BRM10 S06 EMS Fremdbrenner verp	8 718 579 767	■	■	■	■	■	■	■	■	■	■							Zubehör
2	Leitungssatz BRM10 everp	7 747 005 693	■	■	■	■	■	■	■	■	■	■							
3	Fühler Temp RD 6,0 10k BRM10 FK verp	7 747 005 695	■	■	■	■	■	■	■	■	■	■							Zubehör
5	Anschlussklemme 7-polig BR I grün everp	7 747 023 989	■	■	■	■	■	■	■	■	■	■							
6	Anschlusskl. steckb 2-pol schwarz R5 eve	8 718 224 908 0	■	■	■	■	■	■	■	■	■	■							
10	Brennerleitung 2350mm everp	7 747 007 981	■	■	■	■	■	■	■	■	■	■							
11	Steckerteil ST18/7 versilbert everp	6 790 316 4	■	■	■	■	■	■	■	■	■	■							
12	Fühleraufnahmeblech 1/4 Kreis everp	8 718 583 491	■	■	■	■	■	■	■	■	■	■							
13	Blindstück 1/4-kreis (1x) everp	8 718 585 547	■	■	■	■	■	■	■	■	■	■							
14	Ausgleichfeder (5x) everp	8 718 585 143	■	■	■	■	■	■	■	■	■	■							
15	Außentemperaturfühler neutral everp	8 718 585 355	■	■	■	■	■	■	■	■	■	■							
16	Temperaturfühler RD 6,0 10k# 3000mm	7 735 502 295	■	■	■	■	■	■	■	■	■	■							
17	Wärmeleitpaste 20 ML everp	8 719 918 658 0	■	■	■	■	■	■	■	■	■	■							
18	RC310 Buderus weiss RU	7 738 111 128								■									Zubehör
18	RC310 Buderus weiss TR, GR, RO	7 738 112 319					■		■			■							Zubehör
18	RC310 Buderus weiss PL,CZ,SK,SL	7 738 112 369				■		■				■							Zubehör
18	RC310 Buderus weiss DE,AT,LU	7 738 113 410	■																Zubehör
19	RC310 Buderus schwarz RU	7 738 111 127								■									Zubehör
19	RC310 Buderus schwarz TR, GR, RO	7 738 112 318					■		■			■							Zubehör
19	RC310 Buderus schwarz PL,CZ,SK,SL	7 738 112 368				■		■				■							Zubehör
19	RC310 Buderus schwarz DE,AT,LU	7 738 113 411	■																Zubehör
21	Wandmontageset Regler everp	8 737 704 169 0	■	■	■	■	■	■	■	■	■	■							
22	Drehknopf weiß	8 737 714 691	■	■	■	■	■	■	■	■	■	■							
23	Drehknopf schwarz	8 737 712 635	■	■	■	■	■	■	■	■	■	■							
	Adapterblech Regelung MC10 verp	7 747 005 692	■	■	■	■	■	■	■	■	■	■							Zubehör

RMC110

Zubehör, Umbauset
Accessories, Conversion set
Accessoire, Kit de transformation
Accessori, Kit di conversione
Accesorios, Kit de transformación
Akseuar, Dönü#üm Seti

2

Übersetzungsliste List of translations		Liste des traductions Traduzione delle descrizioni		Lista de traducciones Ceviri Listesi	
Pos	Description	Denomination	Descrizione	Descripción	Acıklamalar
1	Element of construction	Groupe de construction	Gruppo di costruzione	Grupo de construccion	Yapi elemanlari
2	Screw M 3.5 x 12 (6x)	Vis M 3.5 x 12 (6x)	Vite M 3,5 x 12 (6x)	Tornillo M 3,5 x 12 (6x)	Vida M 3,5 x 12 (6x)
3	Housing upper part blue	Carter partie superieure bleu	Parte superiore involucro blu	Carcasa superior para conex. Modulos	Gövde üst parçası mavi
4	Housing module carrier white	Module plaque de jonction blanc	Modulo Supporto bianco	Módulo soporte blanco	Modül Taşıyıcı beyaz
5	Fuse application 5x20 6,3AT 230V (10x)	Fusible arrière 5x20 6,3AT 230V (10x)	Fusibile posteriore 5x20 6,3AT 230V(10x)	Fusible 5x20 6,3AT 230V (10x)	Sigorta arka 5x20 6,3AT 230V (10x)
6	Fuseholder cap	Support de fusible	Porta fusibile	Soporte fusible	Sigorta Kapsülü
7	Connector 3-pole white	Borne de connexion 3- pôles blanc	Morsetto di collegamento 3-bipol. bianco	Connector 3-pole white	Bađlantý Klemensi 3- kutuplu beyaz
8	Connector 3-pol. SF50 pink	Borne de raccordement 3-poles SF50 rose	Morsetto di collegamento 3-pol.SF50 rosa	Borne de conexión 3-polos SF50 rosa	Bđlantý klemensi 3-kutuplu SF50 pembe
9	Wire Power HV 1270 Ferrit everp	faisceau de câbles Power HV 1270 Ferrit	Cablaggio Power HV 1270 Ferrit	mazo de cables Power HV 1270 Ferrit	kablo demeti Power HV 1270 Ferrit
11	Connector 4-pol 17B18 orange	Borne de raccordeme 4 poles 17B18 orange	Morsetto di collegamento 4-pol. 17B18	Borne de conexión 4- polos anaranjado	Bađlantý klemensi4-kutuplu 17B18 turuncu
12	Connecting terminal pluggable 3-pol	Borne de connexion 3- pôles jaune	Morsetto di collegamento 3-bipol. giallo	Borne de conexión 3- polos amarillo	Bađlantý Klemensi 3- kutuplu sarı
13	Connector 4-pole SH I violet	Borne de connexion 4- pôles SH I violet	Morsetto di collegame.4-bipol.SH I viol.	Borne de conexión 4- polos SH I violeta	Bađlantý Klemensi 4-pol SH I eflatun
14	Connector 3-pole PS grey	Borne de connexion 3- pôles ps gris	Morsetto di collegamento 3-pol.PS grigio	Connector 3-pole PS grey	Bađlantý Klemensi 3- kutuplu PS gri
15	Connector 3-pole PZ violett	Connecteur 3 poles violet	Morsetto di collegamento - pol.PZ violett	Connector 3-pole PZ violett	Bađlantý Klemensi 3-kutuplu PZ eflatun
16	Connector 3-pole PH green	Borne de connexion 3- pôles PH vert	Morsetto di collegamento 3-pol. PH verde	Connector 3-pole PH green	Bađlantý Klemensi 3-kutuplu PH yesil
18	Connector 3-pol. AS red sparepart	Borne de raccordement 3-poles AS rouge	Morsetto di collegamento3-bipol.AS rosso	Borne de conexión 3-polos AS rojo	Bađlantý klemensi 3-kutuplu AS kırmızı
19	Connecting terminal 2-polig WA maygreen	Fiche verte 2 poles wa	Morsetto di collegamento2-bipol WA verde	Borne de conexión 2-polos WA verde	Bađlantý Klemensi 2-kutuplu WA yesil
20	Connector 2- pin blue	Borne de connexion 2- pol r5 bl everp	Morsetto di collegamento 2-bipolare blu	Borne de conexión 2-polos azul	Bađlantý Klemensi 2-kutuplu mavi
21	Connector 2-pole grey FW	Borne de connexion 2- pôles gris FW	Morsetto di collegame.2-bipol. grigio FW	Borne de conexión 2-polos grey FW	Bađlantý Klemensi 2-kutuplu gri FW
22	Connect. term. 2-polig red	Fiche rouge 2 poles	Morsetto di collegamento2-bipolare rosso	Borne de conexión 2-polos rojo	Bađlantý Klemensi 2-kutuplu kırmızı
23	Connector 2- pin orange RC	Borne de connexion 2- pôles orange RC	Morsetto di collegamento2-bip. arancione	Borne de conexión 2-polos anaranjado RC	Bađlantý Klemensi 2-kutuplu turuncu RC
24	Connector 2-pole white	Borne de connexion 2-poles blanc	Morsetto di collegamento2-pol bianco	Connector 2-pole white	Bađlantý Klemensi 2- kutuplu beyaz
30	Housing strain relief control (10x)	Décharge de traction (10x)	Fermo antitrazione (10x)	Retenedor de cable (10x)	Sabitleme Bandı (10x)
31	PCB MC110 S13 blue	Circuit imprimé MC110 S13 bleu	Scheda elettronica MC110 S13 blu	Placa electrónica MC110 S13 azul	Elektronik kart MC110 S13 mavi
34	Strand set bus BC110-IMC110	Jeu de câbles Bus BC110-IMC110	Set di cavi Bus BC110-IMC110	Conjunto cables Bus BC110-IMC110	Kablo seti Bus BC110-IMC110
35	Control_panel BC110 S04	Module de commande BC110 S04	Controllo remoto BC110 S04	Unidad de mando BC110 S04	Kumanda paneli BC110 S04
36	Housing flap BC110	Couvercle BC110	Coperchio BC110	Tapa BC110	Kapak BC110
55	Cover RC3xx black	Revêtement RC3xx noir	Pannello protettivo RC3xx nero	Recubrimiento RC3xx negro	Kapađý RC3xx siyah
	Buderus Logamatic MC110 S13 blue	Buderus Logamatic MC110 S13 blau verp	Buderus Logamatic MC110 S13 blu verp		
	LAN-Cable RJ45 Cat.5 2000	LAN-câble 2000	LAN-Cavo 2000	LAN-cables 2000	LAN-Kablo 2000
	Outdoor temperature sensor	Sonde de température extérieure	Sonda temperatua esterna	Sensor de temperatura exterior	Dýp Hava Sýcaklýk Sensörü
2	Element of construction	Groupe de construction	Gruppo di costruzione	Grupo de construccion	Yapi elemanlari

Übersetzungsliste List of translations		Liste des traductions Traduzione delle descrizioni		Lista de traducciones Ceviri Listesi	
Pos	Description	Denomination	Descrizione	Descripción	Acıklamalar
1	Module BRM10 S06 exhaust/heat gener	Module BRM10 S06 EMS bruleur externe	Modulo BRM10 S06 EMS bruc. Di terzi		Modul BRM10 S06EMS
2	set of cables BRM10	Jeu de câbles BRM10	Set di cavi BRM10	Kit calbe BRM10 everp	Kablo Seti BRM10
3	temperature sensor RD6,0 10k BRM10 FK	Sonde de température RD6,0 10k BRM10 FK	Sensore sicurezza di temperatura RD6,0 1	Sonda de temperatura RD6,0 10k BRM10 FK	sıcaklık Sensörü RD6,0 10k BRM10 FK
5	Connector 7-pole BR I green	Borne de connexion 7- pôles BR I vert	Morsetto collegamento bruciatore 7-poli	Borne de conexión 7- polos BR I verde	Bađlantý Klemensi 7- kutuplu BR I yesil
6	Connecting terminal 2-pol black	Borne de connexion 2- pôles noir	Morsetto di collegamento 2-bipolare nero	Borne de conexión 2- polos negro	Bađlantý Klemensi 2- kutuplu siyah
10	Burner cabel 2350mm long	Cable de bruleur long 2350mm	Linea del bruciatore 2350mm	Cable del quemador 2350mm	Brülör hattý 2350mm
11	Connector part ST18/7 silver-plated	Connect st18/7 argente	Connessione a spina ST18/7 argentata	Clavija ST18/7 plateada	BRÜLÖR BAĐLANTI SOKETİ ST 18/7
12	Adaptor 1/4 circuit	Adaptateur 1/4 circuit	Adattore 1/4	Adaptador 1/4 circuito	Adaptör 1/4 devreli
13	Spacer for 1/4-circle sensor (1x)	SONDE FICTIVE 1/4 (1x)	Sonda orba 1/4 (1x)	Retenedor para sondas 1/4 (1x)	Kör Tapa 1/4 (1x)
14	Spring compensating (5x) packed	RESSORT DE COMPENSATION (5x)	Compensatore (5x)	Chapa para sonda (5x)	Dengeleme Parçasý (5x)
15	Outdoor temperature sensor	Sonde de température extérieure	Sonda temperatura esterna	Sensor de temperatura exterior	Dýb Hava Sıcaklık Sensörü
16	Temperature sensor RD 6,0 10k# 3000mm	Sonde de température RD6,0 10kOHM 3000mm	Sonda di temperatura RD 6,0 10k# 3000mm	Sensor de temperatura RD 6,0 10k# 3000mm	ıcaklık Sensörü RD 6,0 10k# 3000mm
17	Heat conducting paste 20 ML	Pate Thermocond. 20 ML.	Pasta termoconduttrice 20 ML	Pasta termoconductora 20 ML	Isi Transfer Macunu 20 ML
18	RC310 Buderus White RU				
18	RC310 Buderus White TR, GR, RO				
18	RC310 Buderus White PL,CZ,SK,SL				
18	RC310 Buderus white DE,AT,LU	RC310 Buderus weiss DE,AT,LU			
19	RC310 Buderus black RU				
19	RC310 Buderus black TR, GR, RO				
19	RC310 Buderus Black PL,CZ,SK,SL				
19	RC310 Buderus black DE,AT,LU	RC310 Buderus schwarz DE,AT,LU			
21	Wall mounting bracket	Barre d'accrochage	Supporto a parete	Soporte a la pared	Aský Sacý
22	Rotary knob white	Bouton de réglage blanc	Manopola bianco	Botón giratorio blanco	Kumanda Düđmesi Beyaz
23	Rotary knob black	Bouton de réglage noir	Manopola nero	Botón giratorio negro	Kumanda Düđmesi Siyah
	plate for control unit MC10	Tôle de protection MC10	Lamiera di fissaggio MC10	Chapa de sujeción MC10	Tespit Sacý MC10

Gerätetypen Types of appliances	Types de chaudières Tipo apparecchi	Tipos de aplicaciones Cihaz Cesiitleri	Bemerkungen Remarks Remarques Osservazioni Observaciones Notlar
Gerät Appliance Chaudière Apparecchio Aparato Cihaz	Bestell-Nr. Ordering no. Numéro de commande N° d'ordine Número el ordenar Ordering no.	Land Country Pays Paese Paese Ulke	
MC110	7 736 602 778	Algerien	
MC110	7 736 604 094	Algerien	
MC110	7 736 601 579	Belgien, Deutschland, Griechenland, Italien	
Set MC110, BRM10, RC310	7 736 601 580	Belgien, Deutschland, Luxemburg, Österreich	
MC110	7 736 603 292	Belgien, Italien, Schweiz, Türkei	
Set MC110, BRM10, RC310	7 736 603 303	Estland, Lettland, Litauen, Russische Föder	
Set MC110, BRM10, RC310	7 736 603 812	Griechenland	
MC110	7 736 602 700	Kasachstan, Russische Föderation, Weißruss	
Set MC110, BRM10, RC310	7 736 603 816	Polen	
MC110	7 736 603 293	Polen, Slowakei, Tschechien, Ukraine	
Set MC110, BRM10, RC310	7 736 603 811	Rumänien	
Set MC110, BRM10, RC310	7 736 603 814	Slowakei	
Set MC110, BRM10, RC310	7 736 603 815	Tschechien	
Set MC110, BRM10, RC310	7 736 603 813	Türkei	

Bosch Thermotechnik GmbH
Sophienstr. 30-32
D-35576 Wetzlar / Germany

Buderus