

WLW MB-4-7

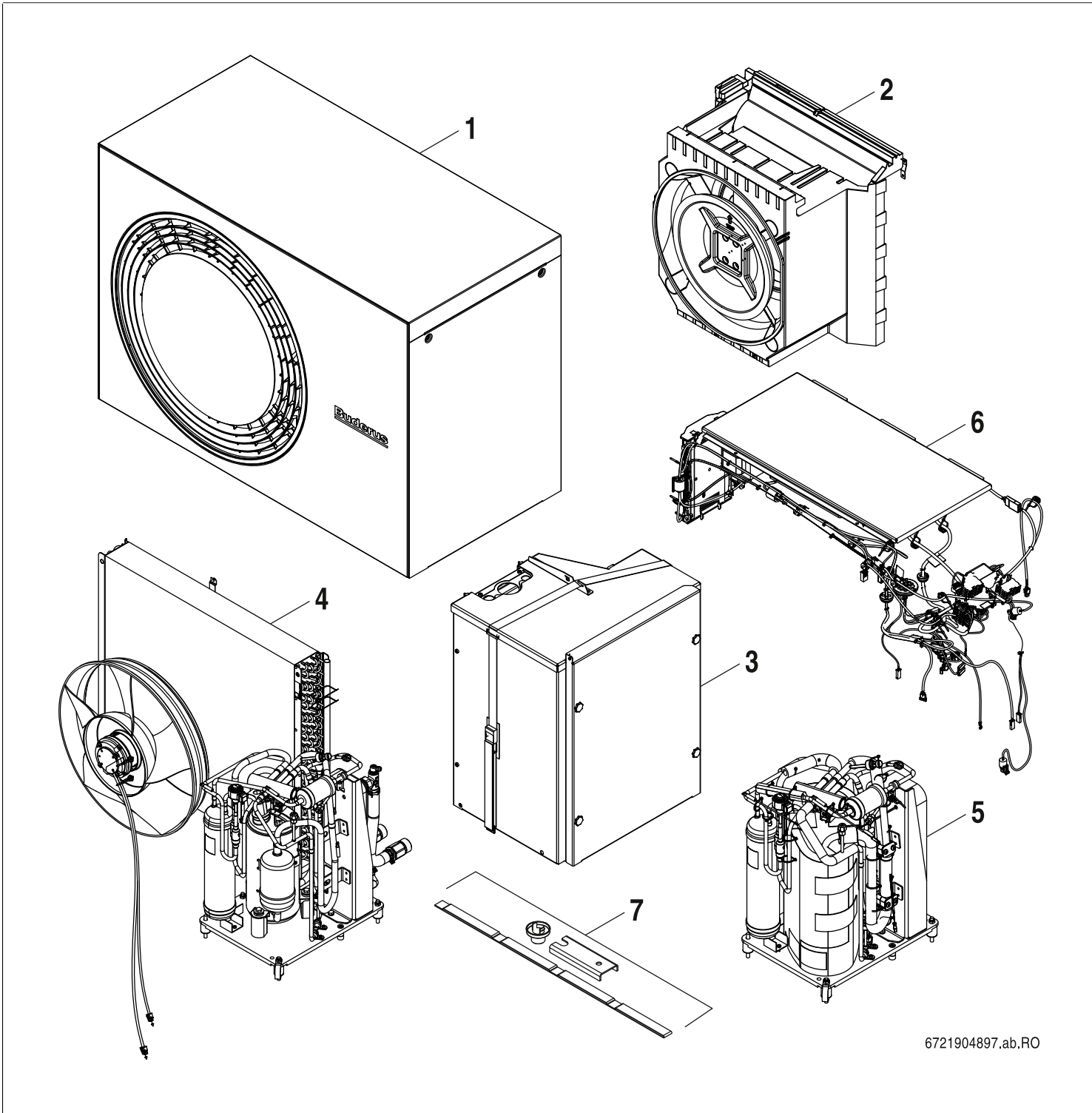

6721904897.ab.RO

[de] Wichtige Hinweise zur Installation/Montage

Die Installation/Montage muss durch eine für die Arbeiten zugelassene Fachkraft unter Beachtung der geltenden Vorschriften erfolgen.

[en] Important notes on installation/assembly

The installation/assembly must be carried out by a qualified contractor, following these instructions and in compliance with the applicable regulations.

[fr] Instructions importantes pour l'installation/le montage

L'installation/le montage doit être effectué(e) par un spécialiste qualifié pour les opérations concernées et dans le respect de la présente notice et des prescriptions applicables.

[bg] Важни указания във връзка с инсталацията/монтажа

Инсталацията/монтажът трябва да се извършва от лицензиран за работите специалист в съответствие с настоящото ръководство и с приложимите разпоредби.

[cs] Důležité pokyny k instalaci/montáži

Instalaci/montáž musí při dodržení pokynů uvedených v tomto návodu a platných předpisů provést odborný pracovník s příslušným oprávněním pro tyto práce.

[da] Vigtige anvisninger til installationen/monteringen

Installationen/monteringen skal foretages af en godkendt installatør under overholdelse af denne vejledning og de gældende forskrifter.

[el] Σημαντικές υποδείξεις για την εγκατάσταση/συναρμολόγηση

Η εγκατάσταση/τοποθέτηση πρέπει να ανατίθεται σε εκπαιδευμένο για τις συγκεκριμένες εργασίες τεχνικό προσωπικό με τήρηση αυτών των οδηγιών καθώς και των σχετικών προδιαγραφών.

[es] Indicaciones importantes para instalación/montaje

La instalación/el montaje debe realizarla personal especializado que esté autorizado para realizar estos trabajos y que tenga en cuenta estas instrucciones y la normativa vigente.

[et] Olulised juhised paigaldamiseks/montaažiks

Paigaldamist/montaaži tohib läbi viia vaid selleks volitusi omav spetsialist, arvestades kehtivaid nõudeid.

[nl-BE] Belangrijke aanwijzingen betreffende de installatie/montage

De installatie/montage moet worden uitgevoerd door een voor de werkzaamheden geautoriseerde installateur rekening houdend met deze handleiding en de geldende voorschriften.

[fi] Tärkeitä asennus- ja kokoonpano-ohjeita

Näihin töihin hyväksytyyn ammattiasentajan pitää suorittaa asennus- ja kokoonpanotyöt voimassa olevien määräysten mukaisesti.

[hr] Važne upute za Instalaciju/Montažu

Instalacija/montaža mora biti izvedena od strane kvalificiranog stručnog osoblja, poštujući ove Upute i u skladu sa važećim propisima.

[hu] Fontos tudnivalók az installáláshoz/szereléshez

A telepítés/szerelés egy, a munkálatokra felhatalmazott szakembernek kell végeznie, jelen utasítás és az érvényes előírások figyelembevételével.

[it] Avvertenze importanti per l'installazione/il montaggio

L'installazione/il montaggio deve aver luogo ad opera di una ditta specializzata ed autorizzata in osservanza di queste istruzioni e delle direttive vigenti.

[ka] მნიშვნელოვანი მითითებები ინსტალაციისთვის/მონტაჟისთვის

ინსტალაცია/მონტაჟი უნდა განხორციელდეს სამუშაოებისთვის დაშვებული კვალიფიციური პერსონალის მიერ, მოქმედი განაწესის დაცვით.

[lt] Svarbios instaliavimo ir (arba) montavimo nuorodos

Instaliavimo/montavimo darbus, laikydamiesi šios instrukcijos reikalavimų ir galiojančių taisyklių, privalo atlikti šioms darbams įgalioti specialistai.

[sq] Shënime të rëndësishme për instalimin/montimin

Instalimi/montimi duhet të bëhet nga një kontraktues i kualifikuar, duke ndjekur këto udhëzime dhe në përputhje me rregulloret në fuqi.

[lv] Svarīgi norādījumi par iekārtas uzstādīšanu / montāžu

Uzstādīšanu/montāžu jāveic atbilstošajiem darbiem sertificētam speciālistam, ievērojot šo instrukciju un spēkā esošos noteikumus.

[nl] Belangrijke aanwijzingen betreffende de installatie/montage

De installatie/montage moet door een erkend installateur volgens de geldende voorschriften worden uitgevoerd.

[no] Viktig informasjon om installasjon/montering

Installasjonen/monteringen skal gjennomføres av autoriserte installatører, og installasjonsanvisningen samt gjeldende forskrifter skal følges.

[pl] Ważne wskazówki dotyczące instalacji/montażu

Instalację/montaż powinien wykonać specjalista uprawniony do tego typu prac z uwzględnieniem informacji podanych w niniejszej instrukcji oraz aktualnie obowiązujących przepisów.

[pt] Indicações importantes relativas à instalação/montagem

A instalação/montagem deve ser efectuada por um técnico autorizado para os trabalhos, respeitando este manual e as prescrições válidas.

[ro] Indicații importante privind instalarea/montajul

Instalarea/montajul trebuie realizate de către un specialist autorizat pentru lucrările respective, respectându-se prezentele instrucțiuni și prescripțiile valabile.

[ru] Важные указания по подключению/монтажу

Подключение/монтаж должны выполнять только специалисты, имеющие допуск к выполнению таких работ, при соблюдении требований этой инструкции и действующих норм и правил.

[sk] Dôležité pokyny týkajúce sa inštalácie/montáže

Inštaláciu/montáž musí vykonať odborný personál, ktorý má oprávnenie pre výkon týchto prác, pričom musí dodržiavať pokyny uvedené v tomto návode a platné predpisy.

[sl] Pomembni napotki za namestitvev/montažo

Inštalacijo/montažo lahko izvede samo pooblaščen strokovnjak ob upoštevanju teh navodil in veljavnih predpisov.

[sr] Važna uputstva za ugradnju i montažu

Ovu instalaciju/montažu moraju da obave stručna lica koja su ovlašćena za obavljanje takvih radova u skladu sa ovim uputstvom i važećim propisima.

[sv] Viktiga anvisningar för installation/montering

Installationen/monteringen måste utföras av en behörig och tekniskt utbildad person enligt denna anvisning samt gällande föreskrifter.

[tr] Kurulum/Montaj ile ilgili önemli uyarılar

Kurulum/montaj, bu çalışmaları yapmasına müsaade edilen uzman kişiler tarafından işbu kılavuz ve geçerli yönetmelikler dikkate alınarak yapılmalıdır.

[uk] Важливі вказівки щодо установки/монтажу

Встановлення/монтаж повинні виконувати фахівці, що допущені до виконання таких робіт, із дотриманням цієї інструкції та діючих приписів.

[zh] 安装方面的重要提示

安装和组装工作必须由经过许可的专业人员进行，同时必须遵守本说明书和现行法规的相关要求

[ar] ملاحظات هامة للتجميع

يجب أن يتم التجميع من قبل متخصص مصرح له بالعمل، مع مراعاة اللوائح السارية.

[fa] تذکرات مهم درباره نصب/مونتاژ

نصب/مونتاژ باید توسط فردی حرفه ای که مجاز به انجام این کار است، و همچنین با توجه کامل به مقررات مربوطه انجام شود.

[az] Quraşdırılma

Quraşdırılma işinin yerinə yetirilməsi səlahiyyətli bir mütəxəssis tərəfindən və müvafiq qaydalara uyğun olaraq aparılmalıdır.

Ersatzteilliste
Liste des pièces de rechange

Lista parti di ricambio
Spare parts list

Onderdelenlijst

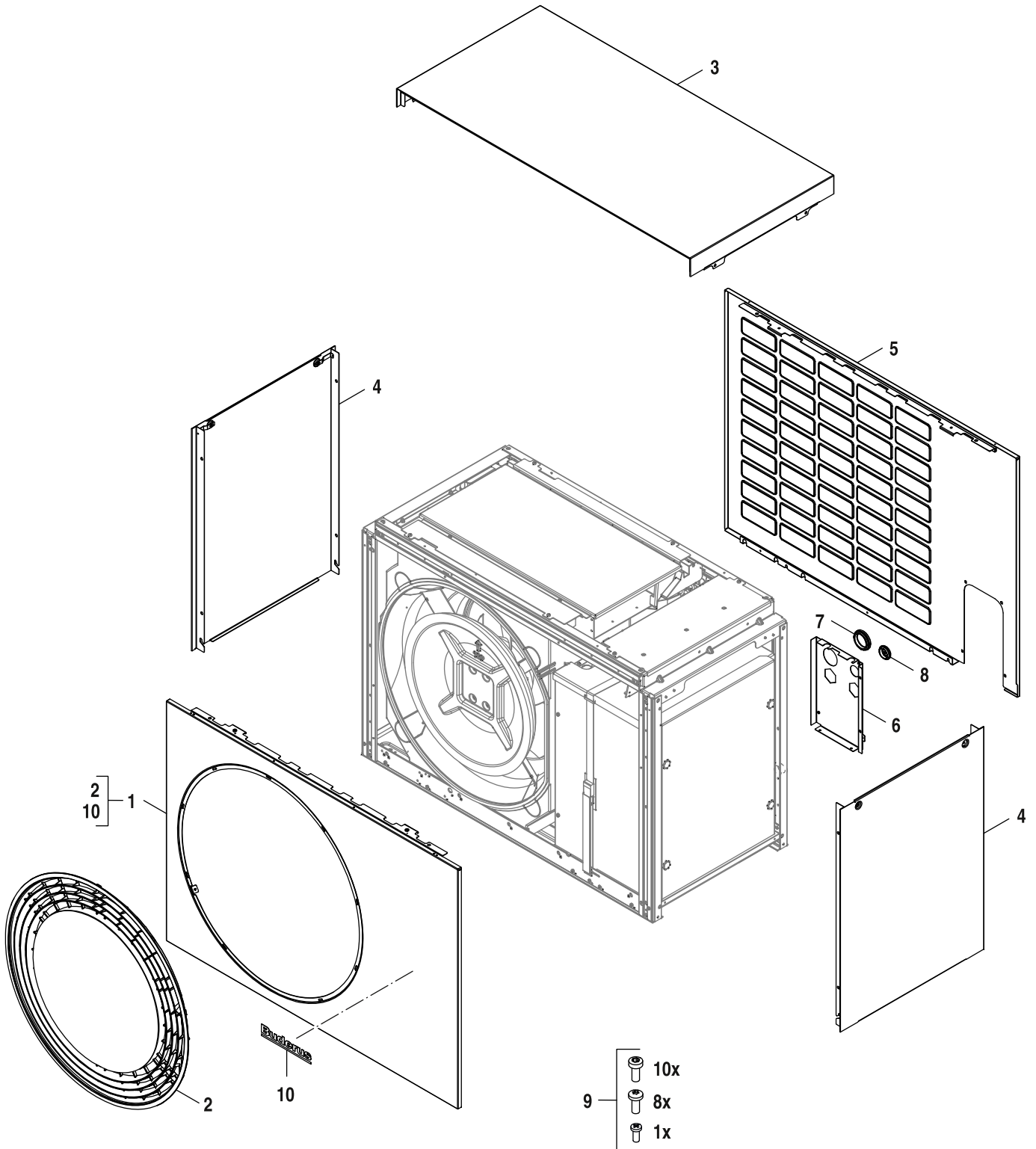

6721904899.ac.RO

1

Verkleidung Bu
Habillage Bu
Mantello Bu
Casing Bu
Toestelmantel Bu

WLW MB-4-7

Pos	Bezeichnung Dénomination Descrizioni Description Benaming		WLW-4 MB AR	WLW-5 MB AR	WLW-7 MB AR																Bemerkungen Remarques Osservazioni Remarks Opmerkingen
1	Vorderwand schwarz	8 738 214 807	■	■	■																
2	Diffusor schwarz	8 738 214 809	■	■	■																
3	Abdeckung oben	8 738 214 811	■	■	■																
4	Seitenteil silber	8 738 214 812	■	■	■																
5	Rückwand schwarz	8 738 214 814	■	■	■																
6	Deckel hinten schwarz	8 738 214 815	■	■	■																
7	Kabeldurchführung	8 738 213 889	■	■	■																
8	Kabeldurchführung M32	8 738 213 890	■	■	■																
9	Montage-Set (Verkleidung)	8 738 213 895	■	■	■																
10	Logo Buderus l = 185 mm	8 738 214 964	■	■	■																

WLW MB-4-7	Verkleidung Bu Habillage Bu Mantello Bu Casing Bu Toestelmantel Bu	1
-------------------	--	----------

Ersatzteilliste
Liste des pièces de rechange

Lista parti di ricambio
Spare parts list

Onderdelenlijst

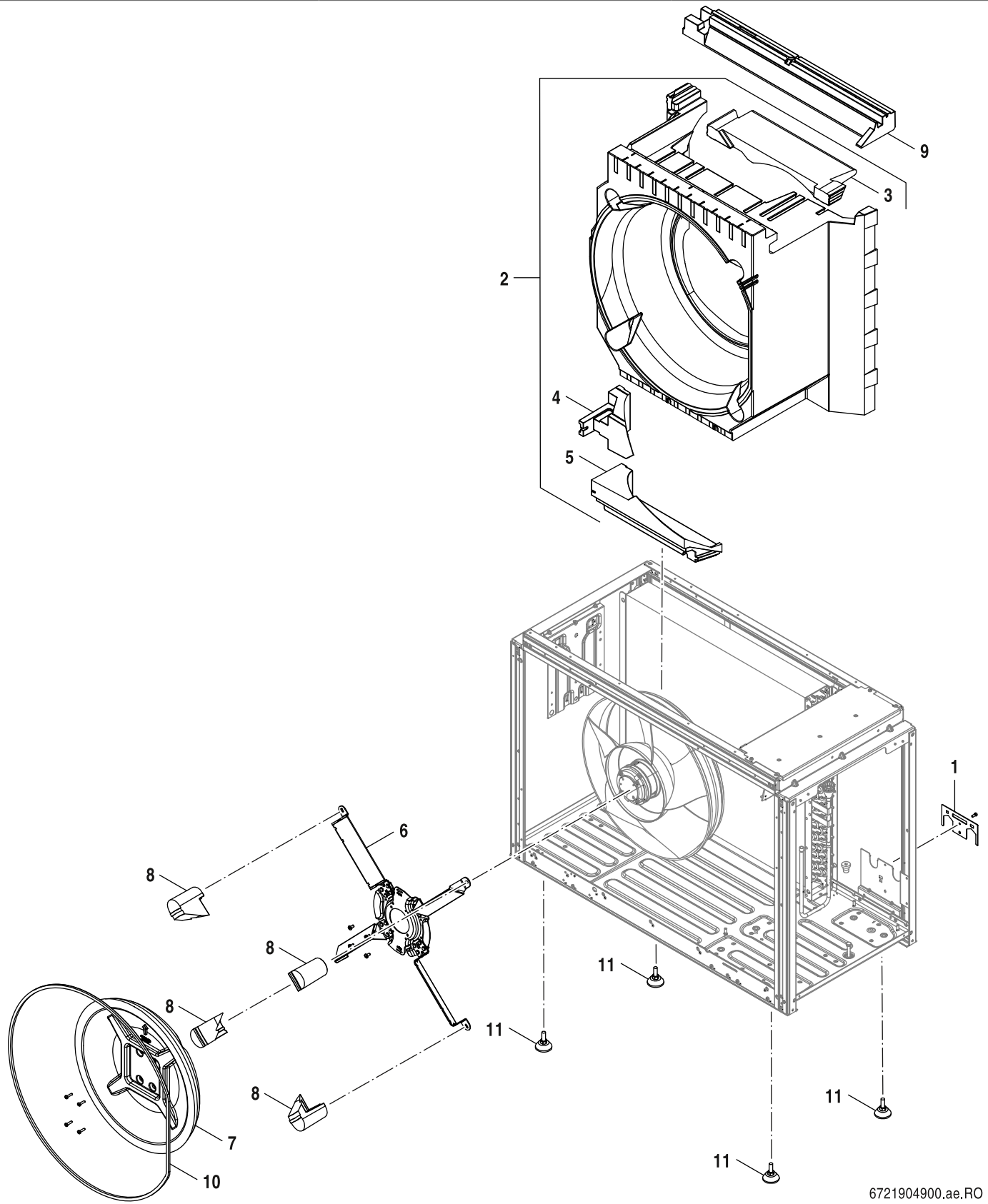

6721904900.ae.RO

- 2**
- Gehäuse EPP
 - Carter EPP
 - Involucro EPP
 - Casing EPP
 - Behuizing EPP

WLW MB-4-7

Pos	Bezeichnung Dénomination Descrizioni Description Benaming		WLW-4 MB AR	WLW-5 MB AR	WLW-7 MB AR																Bemerkungen Remarques Osservazioni Remarks Opmerkingen
1	Sicherungsblech	8 738 213 861	■	■	■																
2	Gehäuse Ventilator EPP	8 738 213 850	■	■	■																
3	Dämmung EPP	8 738 213 851	■	■	■																
4	Isolierung EPP seitlich	8 738 213 852	■	■	■																
5	Isolierung EPP seitlich	8 738 213 853	■	■	■																
6	Halter Gebläse	8 738 213 854	■	■	■																
7	Isolierung (Difusor)	8 738 213 855	■	■	■																
8	Isolierung EPP	8 738 213 856	■	■	■																
9	Dämmung EPP	8 738 213 857	■	■	■																
10	Dichtung Gehäuse (EPP)	8 738 213 858	■	■	■																
11	Stellfuss M10x35	8 748 510 085 0	■	■	■																

WLW MB-4-7	Gehäuse EPP Carter EPP Involucro EPP Casing EPP Behuizing EPP	2
-------------------	---	----------

Ersatzteilliste
Liste des pièces de rechange

Lista parti di ricambio
Spare parts list

Onderdelenlijst

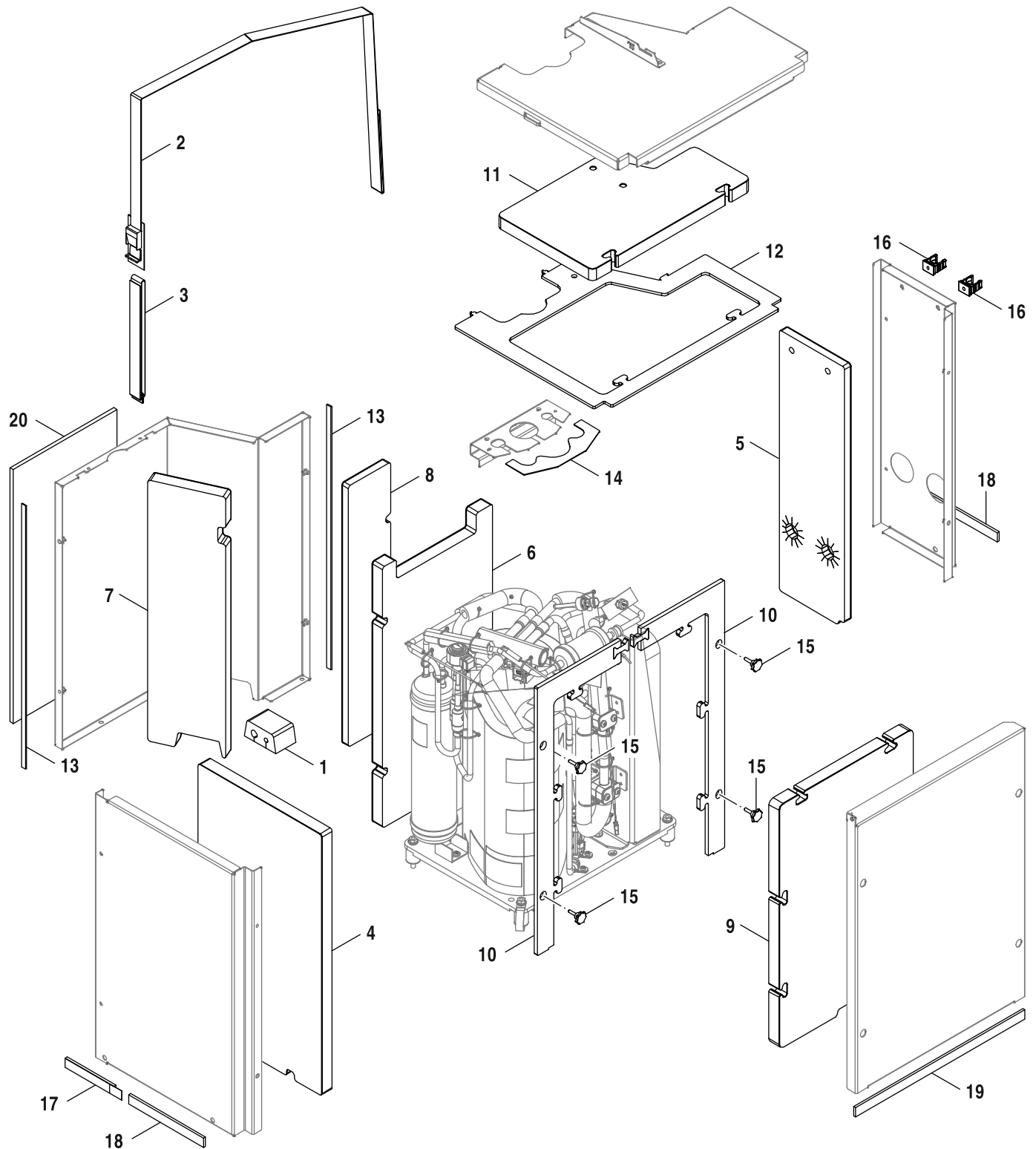

6721904901.aa.RO

3
 Dämmung Kältemittelkreis
 Isolation du circuit de réfrigérant
 Isolamento del circuito frigorifero
 Insulation Rrefrigerant circuit
 Isolatie van koelcircuit

WLW MB-4-7

Pos	Bezeichnung Dénomination Descrizioni Description Benaming		WLW-4 MB AR	WLW-5 MB AR	WLW-7 MB AR																Bemerkungen Remarques Osservazioni Remarks Opmerkingen
1	Dichtung (PE)	8 738 213 863	■	■	■																
2	Spannband hinten	8 738 213 864	■	■	■																
3	Spannband vorne	8 738 213 865	■	■	■																
4	Schalldämmung vorne	8 738 213 866	■	■	■																
5	Schalldämmung hinten	8 738 213 867	■	■	■																
6	Schalldämmung links (276 x 565)	8 738 213 868	■	■	■																
7	Schalldämmung links (148 x 565)	8 738 213 869	■	■	■																
8	Schalldämmung links (106 x 565)	8 738 213 870	■	■	■																
9	Schalldämmung rechts	8 738 213 871	■	■	■																
10	Isolierung seitlich	8 738 213 872	■	■	■																
11	Schalldämmung oben	8 738 213 873	■	■	■																
12	Isolierung oben	8 738 213 874	■	■	■																
13	Dichtband l = 570 mm	8 738 213 875	■	■	■																
14	Dichtplatte	8 738 213 876	■	■	■																
15	Sterngriff D25 M5x20 (4x)	8 738 213 877	■	■	■																
16	Halter Rohr 21,2mm	8 738 211 826	■	■	■																
17	Isolierung vorne	8 738 214 434	■	■	■																
18	Isolierung hinten	8 738 214 435	■	■	■																
19	Isolierung rechts	8 738 214 436	■	■	■																
20	Isolierung links	8 738 214 437	■	■	■																

WLW MB-4-7	Dämmung Kältemittelkreis Isolation du circuit de réfrigérant Isolamento del circuito frigorifero Insulation Rrefrigerant circuit Isolatie van koelcircuit	3
-------------------	---	----------

Ersatzteilliste
Liste des pièces de rechange

Lista parti di ricambio
Spare parts list

Onderdelenlijst

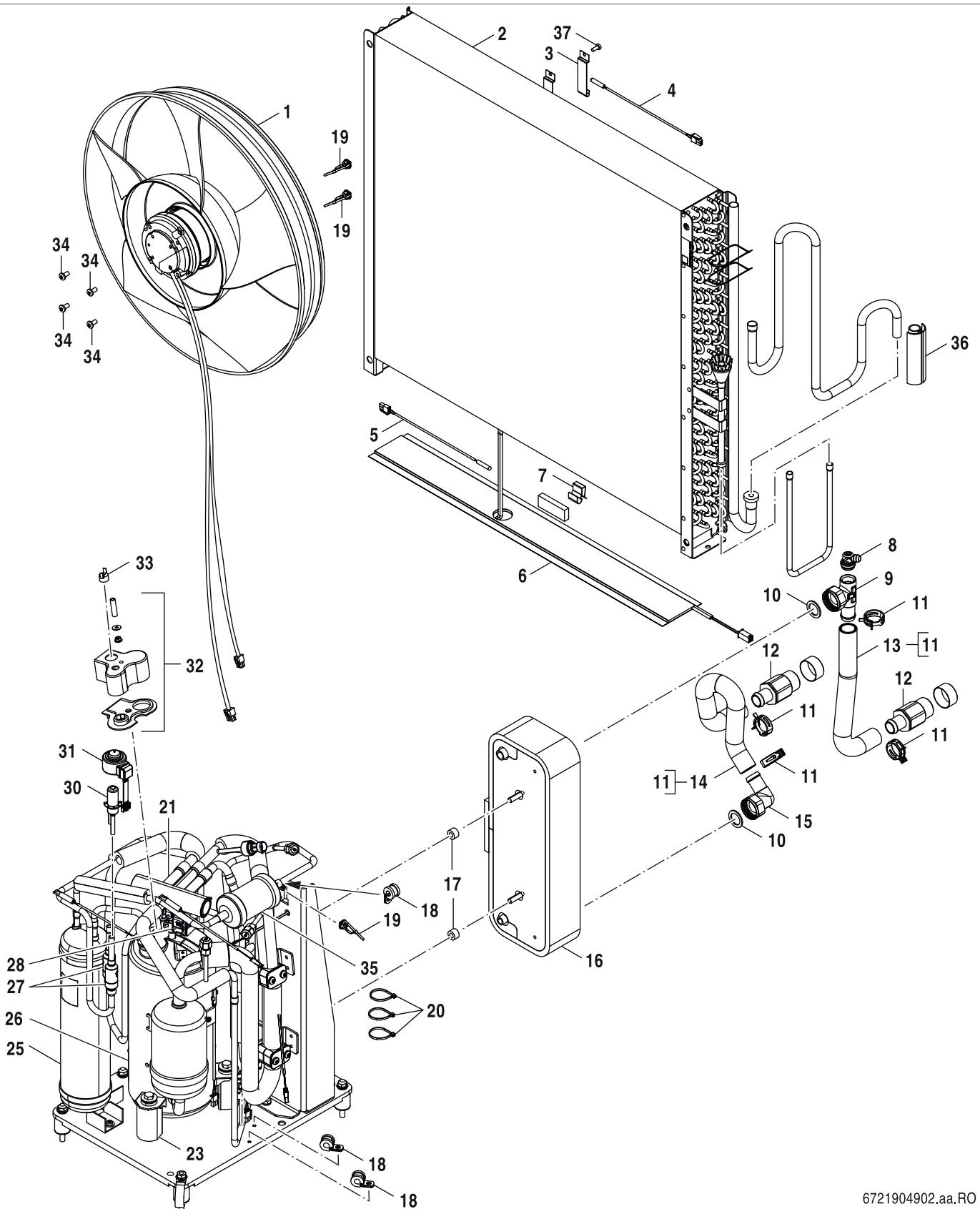

6721904902.aa.RO

4

Kältemittelkreis
 Circuit de réfrigérant
 Circuito del refrigerante
 Rrefrigerant circuit
 Koelmiddelcircuit

WLW MB-4-7

Pos	Bezeichnung Dénomination Descrizioni Description Benaming		WLW-4 MB AR	WLW-5 MB AR	WLW-7 MB AR															Bemerkungen Remarques Osservazioni Remarks Opmerkingen
1	Gebläse D450	8 738 213 841	■	■	■															
2	Verdampfer 7kW	8 738 213 817	■	■	■															
3	Klammer (Temperaturfühler)	8 738 213 821	■	■	■															
4	Temperaturfühler NTC 900mm 4,7kOhm	8 738 203 398	■	■	■															
5	Temperaturfühler NTC 1700mm	8 738 213 818	■	■	■															
6	Heizband	8 738 213 842	■	■	■															
7	Klammer	8 738 213 816	■	■	■															
8	Entlüfter	8 717 405 285 0	■	■	■															
9	T-Stück	8 738 213 840	■	■	■															
10	Dichtung 30x21x2 (10x)	8 711 004 362 0	■	■	■															
11	Klammer (Schlauch)	8 738 213 810	■	■	■															
12	Verbindungsstück 1"	8 738 213 837	■	■	■															
13	Schlauch D = 29 mm, l = 245 mm	8 738 213 838	■	■	■															
14	Schlauch D = 29 mm	8 738 213 824	■	■	■															
15	Winkelverschraubung 1"	8 738 213 839	■	■	■															
16	Plattenwärmetauscher 7 kW	8 738 213 815	■	■	■															
17	Abstandshalter Nylon 8,2x16,0x10,0	8 738 206 790	■	■	■															
18	Schelle 3/8 10 mm	8 738 213 812	■	■	■															
19	Kabelbinder	8 738 211 827	■	■	■															
20	Kabelbinder (10x)	8 738 213 836	■	■	■															
21	4-Wege-Ventil	8 738 213 829	■	■	■															
23	Schwingungsdämpfer	8 738 213 844	■	■	■															
25	Behälter Kältemittel 1,5 L	8 738 213 814	■	■	■															
26	Kompressor Highly WHP07600	8 738 213 843	■	■	■															
27	Filter (Kältemittel)	8 738 211 554	■	■	■															
28	Spule	8 738 213 825	■	■	■															
30	Expansionsventil	8 738 213 827	■	■	■															
31	Spule	8 738 213 826	■	■	■															
32	Abdeckung (Kompressor-Set)	8 738 213 845	■	■	■															
33	Thermosicherung (Kompressor)	8 738 213 846	■	■	■															
34	Schraube M6x12 (4x)	8 738 213 899	■	■	■															
35	Trockenfilter	8 733 702 983	■	■	■															
36	Isolierung	8 738 214 431	■	■	■															
37	Schraube M5x12 (5x)	8 738 213 622	■	■	■															

WLW MB-4-7

Kältemittelkreis
Circuit de réfrigérant
Circuito del refrigerante
Refrigerant circuit
Koelmiddelcircuit

4

Ersatzteilliste
Liste des pièces de rechange

Lista parti di ricambio
Spare parts list

Onderdelenlijst

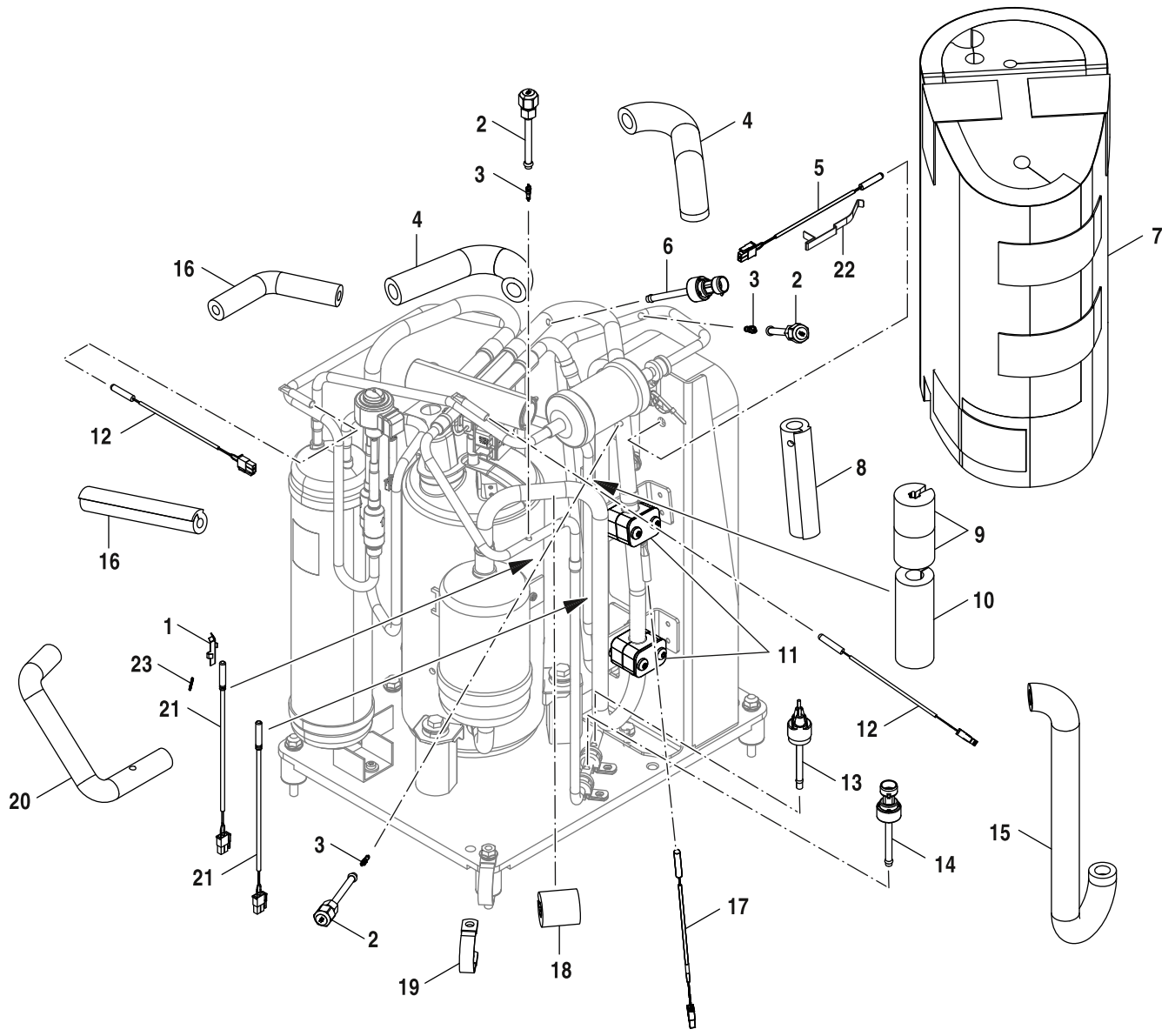

6721904904.ab.RO

5 Fühler und Isolierungen
Sondes et isolations
Sensori e isolamento
Sensors and insulations
Sensoren en isolatie

WLW MB-4-7

Pos	Bezeichnung Dénomination Descrizioni Description Benaming		WLW-4 MB AR	WLW-5 MB AR	WLW-7 MB AR																Bemerkungen Remarques Osservazioni Remarks Opmerkingen
1	Halterung	8 738 213 832	■	■	■																
2	Ventil Schrader 5/16" ASM	8 738 211 579	■	■	■																
3	Einsatz (Ventil)	8 738 211 578	■	■	■																
4	Isolierung 180 mm	8 738 213 830	■	■	■																
5	Temperaturfühler NTC10 1000mm R40 molex	8 738 206 065	■	■	■																
6	Druckfühler	8 738 213 813	■	■	■																
7	Isolierung (Kompressor)	8 738 213 828	■	■	■																
8	Isolierung 120 mm	8 738 213 823	■	■	■																
9	Massedämpfer 15.6 x 43.0mm	8 738 214 432	■	■	■																
10	Isolierung (Temperaturfühler)	8 738 211 506	■	■	■																
11	Schelle	8 738 213 831	■	■	■																
12	Temperaturfühler 200 mm, 10 kOhm	8 733 703 181	■	■	■																
13	Druckschalter	8 738 213 811	■	■	■																
14	Druckfühler	8 738 213 848	■	■	■																
15	Isolierung 450 mm	8 738 213 819	■	■	■																
16	Isolierung 145 mm	8 738 213 822	■	■	■																
17	Temperaturfühler 200mm, 4,7 kOhm	8 733 703 183	■	■	■																
18	Masse-Dämpfer 9.3 x 38.0mm	8 738 214 433	■	■	■																
19	Erdungsband	8 738 213 834	■	■	■																
20	Isolierung 270 mm	8 738 213 820	■	■	■																
21	Temperaturfühler 1000 mm R80	8 738 207 622	■	■	■																
22	Klammer (Tauchhülse)	8 738 214 764	■	■	■																
23	Haltefeder	8 738 213 833	■	■	■																

WLW MB-4-7	Fühler und Isolierungen Sondes et isolations Sensori e isolamento Sensors and insulations Sensoren en isolatie	5
-------------------	--	----------

Ersatzteilliste
Liste des pièces de rechange

Lista parti di ricambio
Spare parts list

Onderdelenlijst

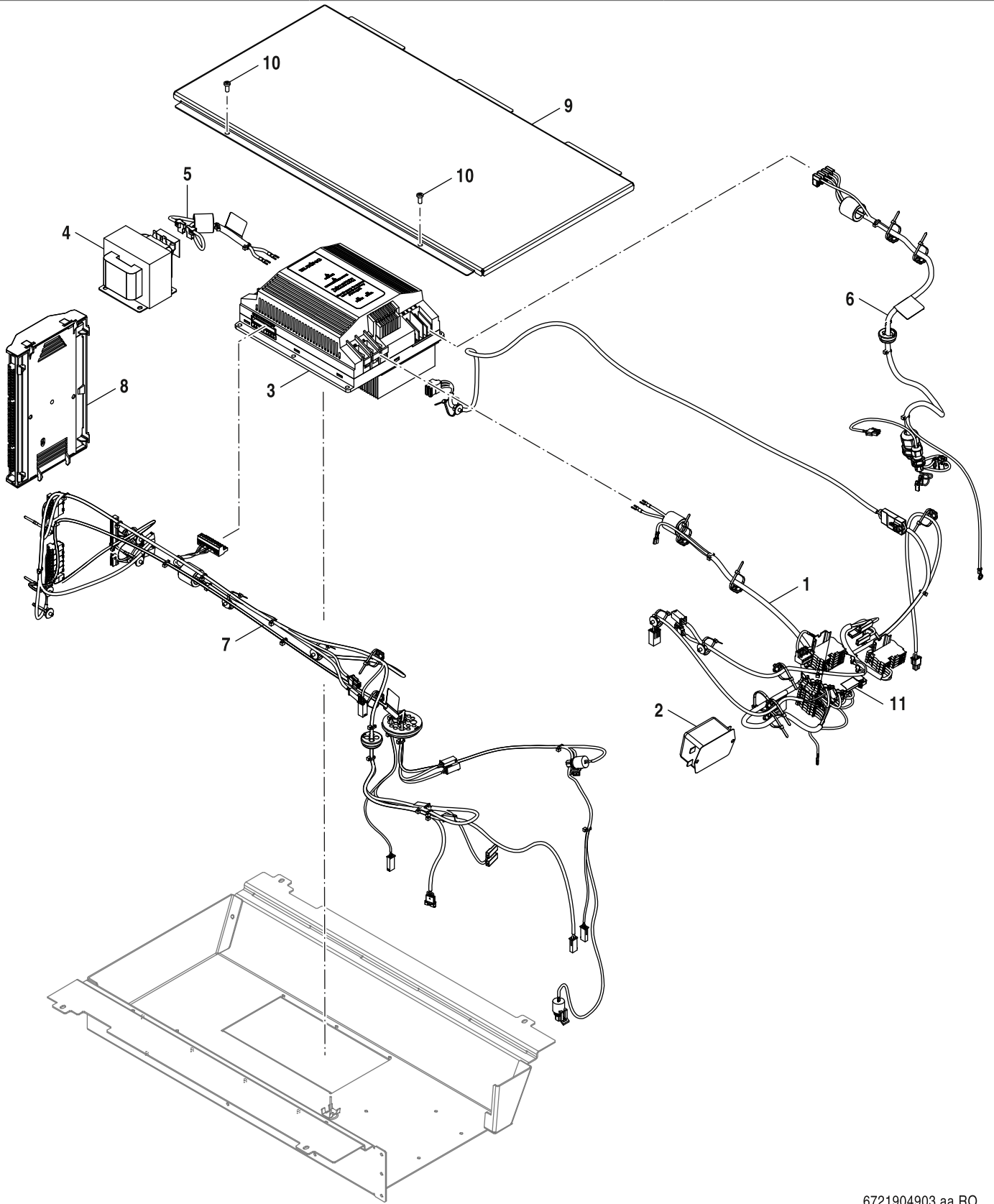

6721904903.aa.RO

6
Regelung
Régulation
Termoregolazione
Control
Regeling

WLW MB-4-7

Pos	Bezeichnung Dénomination Descrizioni Description Benaming		WLW-4 MB AR	WLW-5 MB AR	WLW-7 MB AR																Bemerkungen Remarques Osservazioni Remarks Opmerkingen
1	Kabelbaum	8 738 213 900	■	■	■																
2	Filter EMV	8 738 211 975	■	■	■																
3	Wechselrichter	8 738 213 901	■	■	■																
4	Drosselspule	8 738 213 902	■	■	■																
5	Kabelbaum	8 738 213 903	■	■	■																
6	Kabelbaum Kompressor 7 kW	8 738 213 904	■	■	■																
7	Kabelbaum 7 kW (LV)	8 738 213 905	■	■	■																
8	I/O-Modul XCU-SRH V9.6.0 Uni 4	8 738 216 055	■																		
8	I/O-Modul XCU-SRH V9.6.0 Uni 5	8 738 216 056		■																	
8	I/O-Modul XCU-SRH V9.6.0 Uni 7	8 738 216 057			■																
9	Abdeckung	8 738 213 878	■	■	■																
10	Schraube M5x12 (5x)	8 738 213 622	■	■	■																
11	Relais REL-MR-24DC/21	8 738 214 607	■	■	■																

WLW MB-4-7	Regelung Régulation Termoregolazione Control Regeling	6
-------------------	---	----------

Ersatzteilliste
Liste des pièces de rechange

Lista parti di ricambio
Spare parts list

Onderdelenlijst

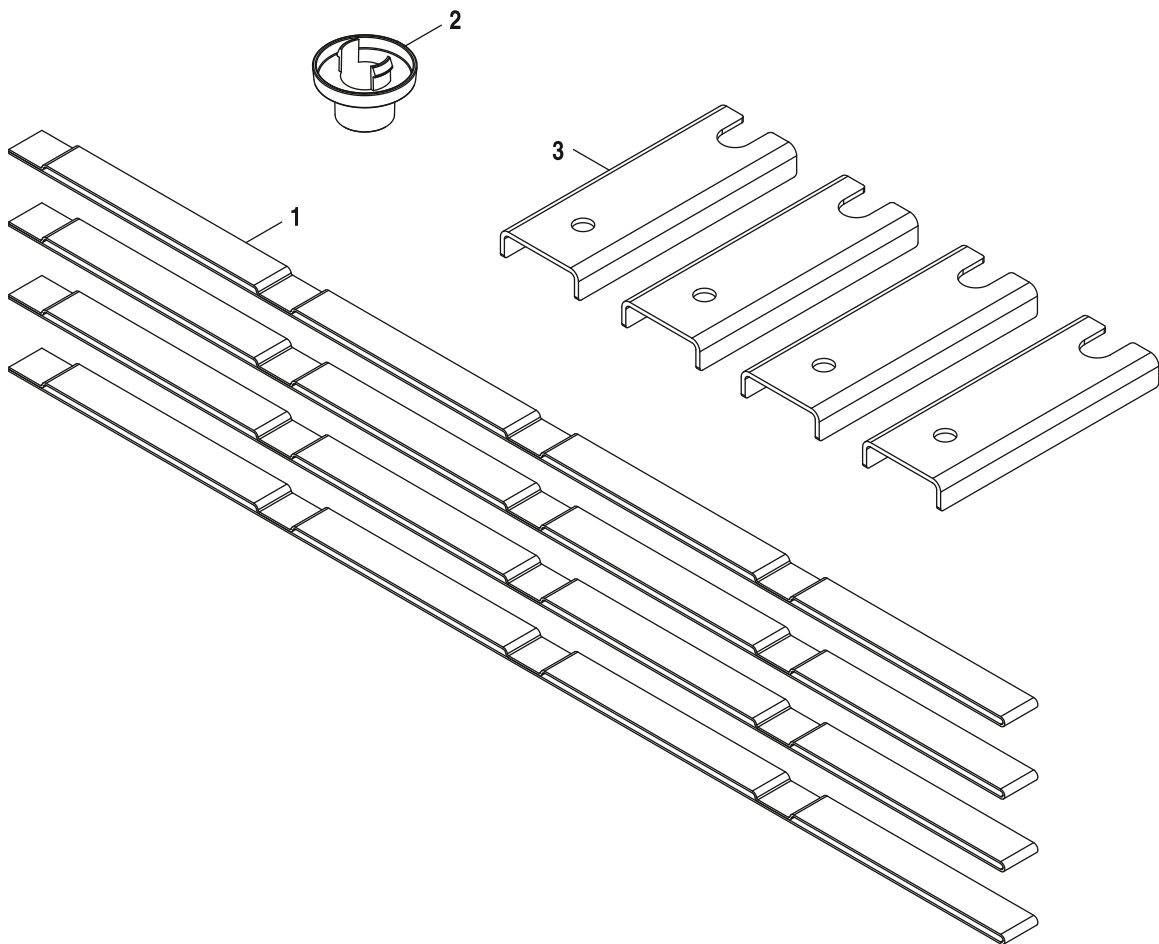

6721905324.aa.RO

7

Zubehör
Accessoire
Accessori
Accessories
Accessoires

WLW MB-4-7

Pos	Bezeichnung Dénomination Descrizioni Description Benaming		WLW-4 MB AR	WLW-5 MB AR	WLW-7 MB AR																Bemerkungen Remarques Osservazioni Remarks Opmerkingen
1	Transportgurt L = 753 mm	8 738 213 862	■	■	■																
2	Kondensatablaufstutzen	8 738 213 860	■	■	■																
3	Halterung (4x)	8 738 215 631	■	■	■																

WLW MB-4-7	Zubehör Accessoire Accessori Accessories Accessoires	7
-------------------	--	----------

Übersetzungsliste		Traduzione delle descrizioni		Vertalinglijst	
Liste des traductions		List of translations			
Pos	Description	Descrizione	Description	Beschrijving	
1	Groupe d'assemblage	Gruppo di montaggio	Element of construction	Montage groep	
1	Panneau avant noir	Pannello anteriore nero	Front panel black	Voorwand zwart	
2	Diffuseur noir	Diffusore nero	Diffuser black	Diffuser zwart	
3	Revêtement haut	Pannello protettivo sopra	Cover top	Afdekking Boven	
4	Panneau latéral argent	Pannello laterale argentato	Side panel silver	Zijpaneel zilver	
5	Panneau arrière noir	Copertura posteriore nero	Backpanel black	Achterwand zwart	
6	Couvercle arrière noir	Coperchio posteriore nero	Cover back black	Deksel Achter zwart	
7	Passe-câbles	Prensa cable	Cable feedthrough	Doorvoertule	
8	Passe-câbles M32	Prensa cable M32	Cable feedthrough M32	Doorvoertule M32	
9	Kit De Montage Pour Habillage	Set di fissaggio (Mantello)	Installation set (Casing)	Montageset (Toestelmantel)	
10	Logo Buderus I = 185 mm	Logo Buderus I = 185 mm	Logo Buderus I = 185 mm	Logo Buderus I = 185 mm	
2	Groupe d'assemblage	Gruppo di montaggio	Element of construction	Montage groep	
1	Tôle de sécurité	Lamiera di sicurezza	Locking plate	Borgplaat	
2	Carter Ventilateur EPP	Involucro Ventilatore EPP	Casing Fan EPP	Behuizing Ventilator EPP	
3	Isolation EPP	Isolamento EPP	Insulation EPP air channel (SC)	Isolatie EPP	
4	Isolation EPP côté	Isolamento elettrico EPP laterale	Insulation EPP side	Isolatie EPP zijkant	
5	Isolation EPP côté	Isolamento elettrico EPP laterale	Insulation EPP side	Isolatie EPP zijkant	
6	Support De Ventilateur	Supporto Ventilatore	Holder Fan	Houder Ventilator	
7	Isolation Du Diffuseur	Isolamento (Difusor)	Insulation (Difusor)	Isolatie (Difusor)	
8	Isolation EPP	Isolamento elettrico EPP	Insulation EPP	Isolatie EPP	
9	Isolation EPP	Isolamento EPP	Insulation EPP top evaporator (SC)	Isolatie EPP	
10	Joint Pour Carter (EPP)	Guarnizione Involucro (EPP)	Gasket Casing (EPP)	Pakking Behuizing (EPP)	
11	PIED M10x35	Vite	Rubber foot M10x35	Stelvoet M10x35	
3	Groupe d'assemblage	Gruppo di montaggio	Element of construction	Montage groep	
1	Joint (PE)	Guarnizione (PE)	Gasket (PE)	Pakking (PE)	
2	Sangle arrière	Fascetta di serraggio posteriore	Fixing strap back	Spanband Achter	
3	Sangle avant	Fascetta di serraggio anteriore	Fixing strap front	Spanband Voor	
4	Isolation acoustique avant	Isolamento acustico anteriore	Sound insulation front	Geluidsdemping Voor	
5	Isolation acoustique arrière	Isolamento acustico posteriore	Sound insulation back	Geluidsdemping Achter	
6	Isolation acoustique gauche (276 x 565)	Isolamento acustico sinistra (276 x 565)	Sound insulation left (276 x 565)	Geluidsdemping Links (276 x 565)	
7	Isolation acoustique gauche (148 x 565)	Isolamento acustico sinistra (148 x 565)	Sound insulation left (148 x 565)	Geluidsdemping Links (148 x 565)	
8	Isolation acoustique gauche (106 x 565)	Isolamento acustico sinistra (106 x 565)	Sound insulation left (106 x 565)	Geluidsdemping Links (106 x 565)	

Übersetzungsliste		Traduzione delle descrizioni		Vertalinglijst	
Liste des traductions		List of translations			
Pos	Description	Descrizione	Description	Beschrijving	
9	Isolation acoustique droite	Isolamento acustico destra	Sound insulation right	Geluidsdemping Rechts	
10	Isolation côté	Isolamento elettrico laterale	Insulation side	Isolatie zijkant	
11	Isolation acoustique haut	Isolamento acustico sopra	Sound insulation top	Geluidsdemping Boven	
12	Isolation haut	Isolamento elettrico sopra	Insulation top	Isolatie Boven	
13	Bande D'Étanchéité Longueur De 570mm	Nastro di tenuta l = 570 mm	Sealing tape l = 570 mm	Afdichtband l = 570 mm	
14	Plaque de scellement	Piastra di tenuta	Sealing plate	Afdichtplaat	
15	Poignée M5x20, Tête D25 (4x)	Maniglia M5x20, testa D25 (4x)	Handle M5x20, Head D25 (4x)	Handgreep M5x20, kop D25 (4x)	
16	Support Tube 21,2mm	Supporto Tubo 21,2mm	Holder pipe 21,2mm	Houder Buis 21,2mm	
17	Isolation avant	Isolamento elettrico anteriore	Insulation front	Isolatie Voor	
18	Isolation arrière	Isolamento elettrico posteriore	Insulation back	Isolatie Achter	
19	Isolation droite	Isolamento elettrico destra	Insulation right	Isolatie Rechts	
20	Isolation gauche	Isolamento elettrico sinistra	Insulation left	Isolatie Links	
4	Groupe d'assemblage	Gruppo di montaggio	Element of construction	Montage groep	
1	Ventilateur D450	Ventilatore D450	Fan D450	Ventilator D450	
2	Évaporateur 7kW	Evaporatore 7kW	Evaporator 7kW	Verdamper 7kW	
3	Clip Pour Sonde De Température	Clip a innesto (Sonda di temperatura)	Clip (Temperature sensor)	Klem (Temperatuursensor)	
4	Sonde de température NTC 900mm 4,7kOhm	Sensore sicurezza di temperatura NTC 900	Temperature sensor NTC 900mm 4,7kOhm	Temperatuursensor NTC 900mm 4,7kOhm	
5	Sonde de température NTC 1700mm	Sonda di temperatura NTC 1700mm	Temperature sensor NTC 1700mm	Temperatuursensor NTC 1700mm	
6	Ruban chauffant	Nastro riscaldante	Heater (Drip Tray)	Verwarmingslint	
7	Clip	Clip a innesto	Clip	Klem	
8	Soupape de ventilation	Disaeratore	Air vent	Ontluchter	
9	Raccord en T	Raccordo a T	Tee	T-stuk	
10	Joint pompes AWM 1" 30x21x2 (10x)	Guarnizione 30x21x2 (10x)	Gasket 1" 30x21x2 (10x)	pakking 30x21x2 (10x)	
11	Clip Pour Tube flexible	Clip a innesto (Tubo flessibile)	Clip (Hose)	Klem (Slang)	
12	Pièce de raccordement 1"	Elemento di collegamento 1"	Connection piece 1"	Rookgasverbindingstuk 1"	
13	Tuyau Souple Diamètre De 29mm, l = 245mm	Tubo flessibile D = 29 mm, l = 245 mm	Hose D = 29 mm, l = 245 mm	Slang D = 29 mm, l = 245 mm	
14	Tuyau Souple Diamètre De 29mm	Tubo flessibile D = 29 mm	Hose D = 29 mm	Slang D = 29 mm	
15	Raccord à vis coudé 1"	Raccordo filettato angolare 1"	Elbow fitting 1"	Haakse schroefverbinding 1"	
16	Échangeur A Plaques 7kW	Scambiatore di calore a piastre 7 kW	Plate heat exchanger 7 kW	Platenwisselaar 7 kW	
17	Entretoise Nylon 8,2x16,0x10,0mm	Distanziale Nylon 8,2x16,0x10,0	Spacer Nylon 8,2x16,0x10,0	Afstandhouder Nylon 8,2x16,0x10,0	
18	Collier 3/8 10 mm	Morsetto 3/8 10 mm	Clamp 3/8 10 mm	Klem 3/8 10 mm	
19	Attache de câbles	Fascetta stringicavi	Cable tie	Kabelbinder	

Übersetzungsliste		Traduzione delle descrizioni		Vertalinglijst	
Liste des traductions		List of translations			
Pos	Description	Descrizione	Description	Beschrijving	
20	Attache de câbles (10x)	Fascetta stringicavi (10x)	Cable tie (10x)	Kabelbinder (10x)	
21	Vanne 4 voies	Organo 4 vie	4-way valve	4-wegklep	
23	Plot antivibratile	Ammortizzatore di vibrazioni	Anti-vibration coupling	Trillingsdemper	
25	Ballon de stockage 1,5 L	Recipiente 1,5 L	Accumulator Refrigerant 1.5L	Reservoir 1,5 L	
26	Compresseur Highly WHP07600	Compressore Highly WHP07600	Compressor Highly WHP07600	Compressor Highly WHP07600	
27	Filtre Pour Réfrigérant	Filtro (Refrigerante)	Filter (Refrigerant)	Filter (Koudemiddel)	
28	Bobine	Bobina	Coil	Spoel	
30	Détendeur	Valvola di espansione	Expansion valve	Expansieventiel	
31	Bobine	Bobina	Coil	Spoel	
32	Couvercle De Jeu Compresseur	Copertura (Kit compressore)	Cover (Compressor kit)	Afdekking (Compressor-set)	
33	Disjoncteur Thermique Du Compresseur	Disgiuntore termico (Compressore)	Thermal cut out (Compressor)	Thermische zekering (Compressor)	
34	Vis M6x12 (4x)	Bullone,vite M6x12 (4x)	Screw M6x12 (4x)	Schroef M6x12 (4x)	
35	Filtre sec ODU	Filtro a secco	Dry filter	Droogfilter	
36	Isolation	Isolamento elettrico	Insulation	Isolatie	
37	Vis M5x12 (5x)	Vite M5x12 (5x)	Screw M5x12 (5x)	Schroef M5x12 (5x)	
5	Groupe d'assemblage	Gruppo di montaggio	Element of construction	Montage groep	
1	Support	Supporto	Bracket	Beugel	
2	Vanne Schrader 5/16" ASM	Valvola Schrader 5/16" ASM	Vavle Schrader ASM	Ventiel Schrader 5/16" ASM	
3	Cartouche De Vanne	Cartuccia (Valvola)	Cartridge (Valve)	Houder (Ventiel)	
4	Isolation 180mm	Coibentazione 180 mm	Insulation 180 mm	Isolatie 180 mm	
5	Sonde de température NTC 1000mm R40 mole	Sensore di temperatura NTC10 1000mm R40	Temperature sensor NTC10 1000mm R40 mol	Temperatuursensor NTC10 1000mm R40 molex	
6	Capteur de pression	Sensore di pressione	Pressure sensor	Druksensor	
7	Isolation Pour Compresseur	Isolamento elettrico (Compressore)	Insulation (Compressor)	Isolatie (Compressor)	
8	Isolation 120mm	Coibentazione 120 mm	Insulation 120 mm	Isolatie 120 mm	
9	Amortisseur de masse 13.7 x 38.1mm	Ammortizzatore di massa 13.7 x 38.1mm	Mass damper 13.7 x 38.1mm	Massademper 13.7 x 38.1mm	
10	Isolation De Sonde De Température	Coibentazione (Sonda di temperatura)	Insulation (Temperature sensor)	Isolatie (Temperatuursensor)	
11	Collier	Morsetto	Clamp	Klem	
12	Sonde de température 200mm, 10 kOhm	Sensore di temperatura 200 mm	Temperature sensor 200 mm, 10 kOhm	Temperatuursensor 200 mm, 10 kOhm	
13	Interrupteur pression	Pressostato	Pressure switch	Drukverschilschakelaar	
14	Capteur de pression	Sensore di pressione	Pressure sensor	Druksensor	
15	Isolation 450mm	Coibentazione 450 mm	Insulation 450 mm	Isolatie 450 mm	
16	Isolation 145mm	Coibentazione 145 mm	Insulation 145 mm	Isolatie 145 mm	

Übersetzungsliste		Traduzione delle descrizioni		Vertalinglijst	
Liste des traductions		List of translations			
Pos	Description	Descrizione	Description	Beschrijving	
17	Sonde de température 200mm, 4,7 kOhm	Sensore di temperatura 200mm,	Temperature sensor 200mm, 4,7 kOhm	Temperatuursensor 200mm, 4,7 kOhm	
18	Amortisseur De Masse 7.8 x 33.0 mm	Ammortizzatore di massa 7.8 x 33.0mm	Mass damper 7.8 x 33.0mm	Massademper 7.8 x 33.0mm	
19	Mise à la terre	Messa a terra	Earthing strap	Aardclip	
20	Isolation 270mm	Coibentazione 270 mm	Insulation 270 mm	Isolatie 270 mm	
21	Sonde de température 1000mm R80	Sonda di temperatura 1000mm R80	Temperature sensor 1000 mm R80	Temperatuursensor 1000mm R80	
22	Clip (Support de sonde)	Clip (Pozzetto ad immersione)	Clip (Sensor pocket)	Klem (Dompelhuls)	
23	Epingle	Molla di ritenzione	Clip	Borgveer	
6	Groupe d'assemblage	Gruppo di montaggio	Element of construction	Montage groep	
1	Faisceau de câbles	Cablaggio	Harness IWI 7Kw	Kabelboom	
2	Filtre EMC	Filtro EMC	Filter EMC	EMC filter	
3	Onduleur	Inverter	Inverter	Omvormer	
4	Serpentin	Bobina	Choke	Spoel	
5	Faisceau de câbles	Cablaggio	Cable harness	Kabelboom	
6	Faisceau De Câbles Pour Compresseur 7kW	Cablaggio Compensore 7 kW	Cable harness Compressor 7 kW	Kabelboom Compressor 7 kW	
7	Faisceau De Câbles 7kW (LV)	Cablaggio 7 kW (LV)	Cable harness 7 kW (LV)	Kabelboom 7 kW (LV)	
8	Module d'E-S XCU-SRH V9.6.0 Uni 4	Modulo I/O XCU-SRH V9.6.0 Uni 4	I/O Module XCU-SRH V9.6.0 Uni 4	I/O-module XCU-SRH V9.6.0 Uni 4	
8	Module d'E-S XCU-SRH V9.6.0 Uni 5	Modulo I/O XCU-SRH V9.6.0 Uni 5	I/O Module XCU-SRH V9.6.0 Uni 5	I/O-module XCU-SRH V9.6.0 Uni 5	
8	Module d'E-S XCU-SRH V9.6.0 Uni 7	Modulo I/O XCU-SRH V9.6.0 Uni 7	I/O Module XCU-SRH V9.6.0 Uni 7	I/O-module XCU-SRH V9.6.0 Uni 7	
9	Couvercle	Copertura	Cover	Afdekking	
10	Vis M5x12 (5x)	Vite M5x12 (5x)	Screw M5x12 (5x)	Schroef M5x12 (5x)	
11	Relais REL-MR-24DC/21	Relè REL-MR-24DC/21	Relay REL-MR-24DC/21	Relais REL-MR-24DC/21	
7	Groupe d'assemblage	Gruppo di montaggio	Element of construction	Montage groep	
1	Sangle De Levage Longueur De 753mm	Imbragatura L = 753 mm	Belt lifting L = 753 mm	Sling L = 753 mm	
2	Prise d'évacuation des condensats	Presa per scarico condensa	Condensate drain socket	Condensaat aftapplug	
3	Support (4x)	Supporto (4x)	Bracket (4x)	Beugel (4x)	

Gerätetypen Types de chaudières		Tipo apparecchi Types of appliances		Toesteltypes	
Gerät Chaudière Apparecchio Appliance Toestel		Land Pays Paese Country Land		Bemerkungen Remarques Osservazioni Remarks Opmerkingen	
WLW-4 MB AR	8 738 213 469	AT,BE,CH,DE,IT,LU,PL			
WLW-5 MB AR	8 738 213 470	AT,BE,CH,DE,IT,LU,PL			
WLW-7 MB AR	8 738 213 471	AT,BE,CH,DE,IT,LU,PL			
WLW-4 MB AR	8 738 215 691	CZ,EE,LT,LV,PL,SK			
WLW-5 MB AR	8 738 215 692	CZ,EE,LT,LV,PL,SK			
WLW-7 MB AR	8 738 215 693	CZ,EE,LT,LV,PL,SK			

Bosch Thermotechnik GmbH
Sophienstr. 30-32
D-35576 Wetzlar / Germany

Buderus