

WLW MB-10-12

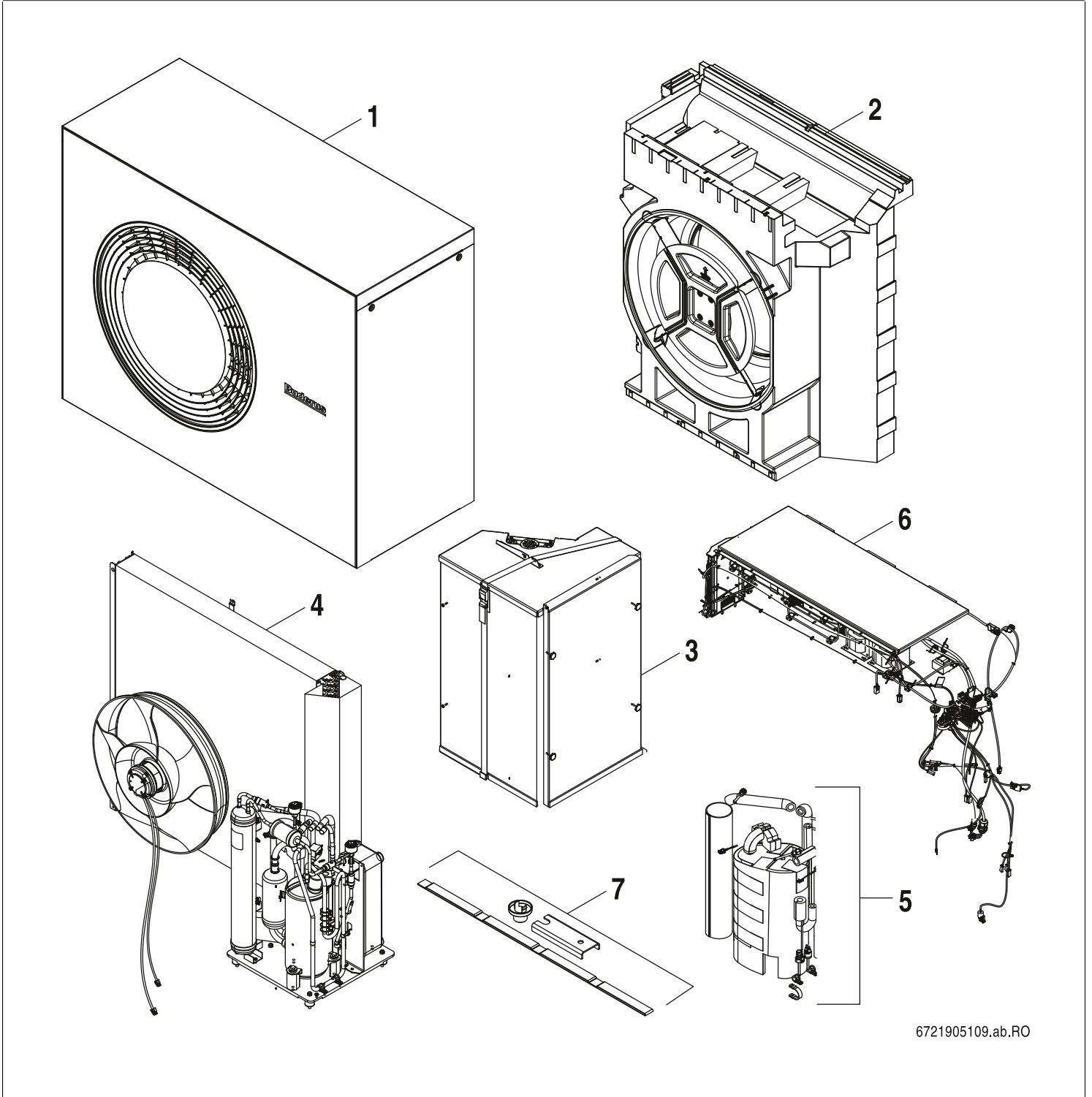

6721905109.ab.RO

[de] Wichtige Hinweise zur Installation/Montage

Die Installation/Montage muss durch eine für die Arbeiten zugelassene Fachkraft unter Beachtung der geltenden Vorschriften erfolgen.

[en] Important notes on installation/assembly

The installation/assembly must be carried out by a qualified contractor, following these instructions and in compliance with the applicable regulations.

[fr] Instructions importantes pour l'installation/le montage

L'installation/le montage doit être effectué(e) par un spécialiste qualifié pour les opérations concernées et dans le respect de la présente notice et des prescriptions applicables.

[bg] Важни указания във връзка с инсталацията/монтажа

Инсталацията/монтажът трябва да се извършва от лицензиран за работите специалист в съответствие с настоящото ръководство и с приложимите разпоредби.

[cs] Důležité pokyny k instalaci/montáži

Instalaci/montáž musí při dodržení pokynů uvedených v tomto návodu a platných předpisů provést odborný pracovník s příslušným oprávněním pro tyto práce.

[da] Vigtige anvisninger til installationen/monteringen

Installationen/monteringen skal foretages af en godkendt installatør under overholdelse af denne vejledning og de gældende forskrifter.

[el] Σημαντικές υποδείξεις για την εγκατάσταση/συναρμολόγηση

Η εγκατάσταση/τοποθέτηση πρέπει να ανατίθεται σε εκπαιδευμένο για τις συγκεκριμένες εργασίες τεχνικό προσωπικό με τήρηση αυτών των οδηγιών καθώς και των σχετικών προδιαγραφών.

[es] Indicaciones importantes para instalación/montaje

La instalación/el montaje debe realizarla personal especializado que esté autorizado para realizar estos trabajos y que tenga en cuenta estas instrucciones y la normativa vigente.

[et] Olulised juhised paigaldamiseks/montaažiks

Paigaldamist/montaaži tohib läbi viia vaid selleks volitusi omav spetsialist, arvestades kehtivaid nõudeid.

[nl-BE] Belangrijke aanwijzingen betreffende de installatie/montage

De installatie/montage moet worden uitgevoerd door een voor de werkzaamheden geautoriseerde installateur rekening houdend met deze handleiding en de geldende voorschriften.

[fi] Tärkeitä asennus- ja kokoonpano-ohjeita

Näihin töihin hyväksytyyn ammattiasentajan pitää suorittaa asennus- ja kokoonpanotyöt voimassa olevien määräysten mukaisesti.

(hr) Važne upute za Instalaciju/Montažu

Instalacija/montaža mora biti izvedena od strane kvalificiranog stručnog osoblja, poštujući ove Upute i u skladu sa važećim propisima.

[hu] Fontos tudnivalók az installáláshoz/szereléshez

A telepítés/szerelés egy, a munkálatokra felhatalmazott szakembernek kell végeznie, jelen utasítás és az érvényes előírások figyelembevételével.

[it] Avvertenze importanti per l'installazione/il montaggio

L'installazione/il montaggio deve aver luogo ad opera di una ditta specializzata ed autorizzata in osservanza di queste istruzioni e delle direttive vigenti.

[ka] მნიშვნელოვანი მითითებები ინსტალაციისთვის/მონტაჟისთვის

ინსტალაცია/მონტაჟი უნდა განხორციელდეს სამუშაოებისთვის დაშვებული კვალიფიციური პერსონალის მიერ, მოქმედი განაწესის დაცვით.

[lt] Svarbios instaliavimo ir (arba) montavimo nuorodos

Instaliavimo/montavimo darbus, laikydamiesi šios instrukcijos reikalavimų ir galiojančių taisyklių, privalo atlikti šioms darbams įgalioti specialistai.

[sq] Shënime të rëndësishme për instalimin/montimin

Instalimi/montimi duhet të bëhet nga një kontraktues i kualifikuar, duke ndjekur këto udhëzime dhe në përputhje me rregulloret në fuqi.

[lv] Svarīgi norādījumi par iekārtas uzstādīšanu / montāžu

Uzstādīšanu/montāžu jāveic atbilstošajiem darbiem sertificētam speciālistam, ievērojot šo instrukciju un spēkā esošos noteikumus.

[nl] Belangrijke aanwijzingen betreffende de installatie/montage

De installatie/montage moet door een erkend installateur volgens de geldende voorschriften worden uitgevoerd.

[no] Viktig informasjon om installasjon/montering

Installasjonen/monteringen skal gjennomføres av autoriserte installatører, og installasjonsanvisningen samt gjeldende forskrifter skal følges.

[pl] Ważne wskazówki dotyczące instalacji/montażu

Instalację/montaż powinien wykonać specjalista uprawniony do tego typu prac z uwzględnieniem informacji podanych w niniejszej instrukcji oraz aktualnie obowiązujących przepisów.

[pt] Indicações importantes relativas à instalação/montagem

A instalação/montagem deve ser efectuada por um técnico autorizado para os trabalhos, respeitando este manual e as prescrições válidas.

[ro] Indicații importante privind instalarea/montajul

Instalarea/montajul trebuie realizate de către un specialist autorizat pentru lucrările respective, respectându-se prezentele instrucțiuni și prescripțiile valabile.

[ru] Важные указания по подключению/монтажу

Подключение/монтаж должны выполнять только специалисты, имеющие допуск к выполнению таких работ, при соблюдении требований этой инструкции и действующих норм и правил.

[sk] Dôležité pokyny týkajúce sa inštalácie/montáže

Inštaláciu/montáž musí vykonať odborný personál, ktorý má oprávnenie pre výkon týchto prác, pričom musí dodržiavať pokyny uvedené v tomto návode a platné predpisy.

[sl] Pomembni napotki za namestitvev/montažo

Inštalacijo/montažo lahko izvede samo pooblaščen strokovnjak ob upoštevanju teh navodil in veljavnih predpisov.

[sr] Važna uputstva za ugradnju i montažu

Ovu instalaciju/montažu moraju da obavne stručna lica koja su ovlašćena za obavljanje takvih radova u skladu sa ovim uputstvom i važećim propisima.

[sv] Viktiga anvisningar för installation/montering

Installationen/monteringen måste utföras av en behörig och tekniskt utbildad person enligt denna anvisning samt gällande föreskrifter.

[tr] Kurulum/Montaj ile ilgili önemli uyarılar

Kurulum/montaj, bu çalışmaları yapmasına müsaade edilen uzman kişiler tarafından işbu kılavuz ve geçerli yönetmelikler dikkate alınarak yapılmalıdır.

[uk] Важливі вказівки щодо установки/монтажу

Встановлення/монтаж повинні виконувати фахівці, що допущені до виконання таких робіт, із дотриманням цієї інструкції та діючих приписів.

[zh] 安装方面的重要提示

安装和组装工作必须由经过许可的专业人员进行，同时必须遵守本说明书和现行法规的相关要求

[ar] ملاحظات هامة للتثبيت/التجميع

يجب أن يتم التثبيت/التجميع من قبل متخصص مصرح له بالعمل، مع مراعاة اللوائح السارية.

[fa] تذکرات مهم درباره نصب/مونتاژ

نصب/مونتاژ باید توسط فردی حرفه ای که مجاز به انجام این کار است، و همچنین با توجه کامل به مقررات مربوطه انجام شود.

[az] Quraşdırılma

Quraşdırılma işinin yerinə yetirilməsi səlahiyyətli bir mütəxəssis tərəfindən və müvafiq qaydalara uyğun olaraq aparılmalıdır.

Ersatzteilliste
Spare parts list

Liste des pièces de rechange
Lista parti di ricambio

Onderdelenlijst

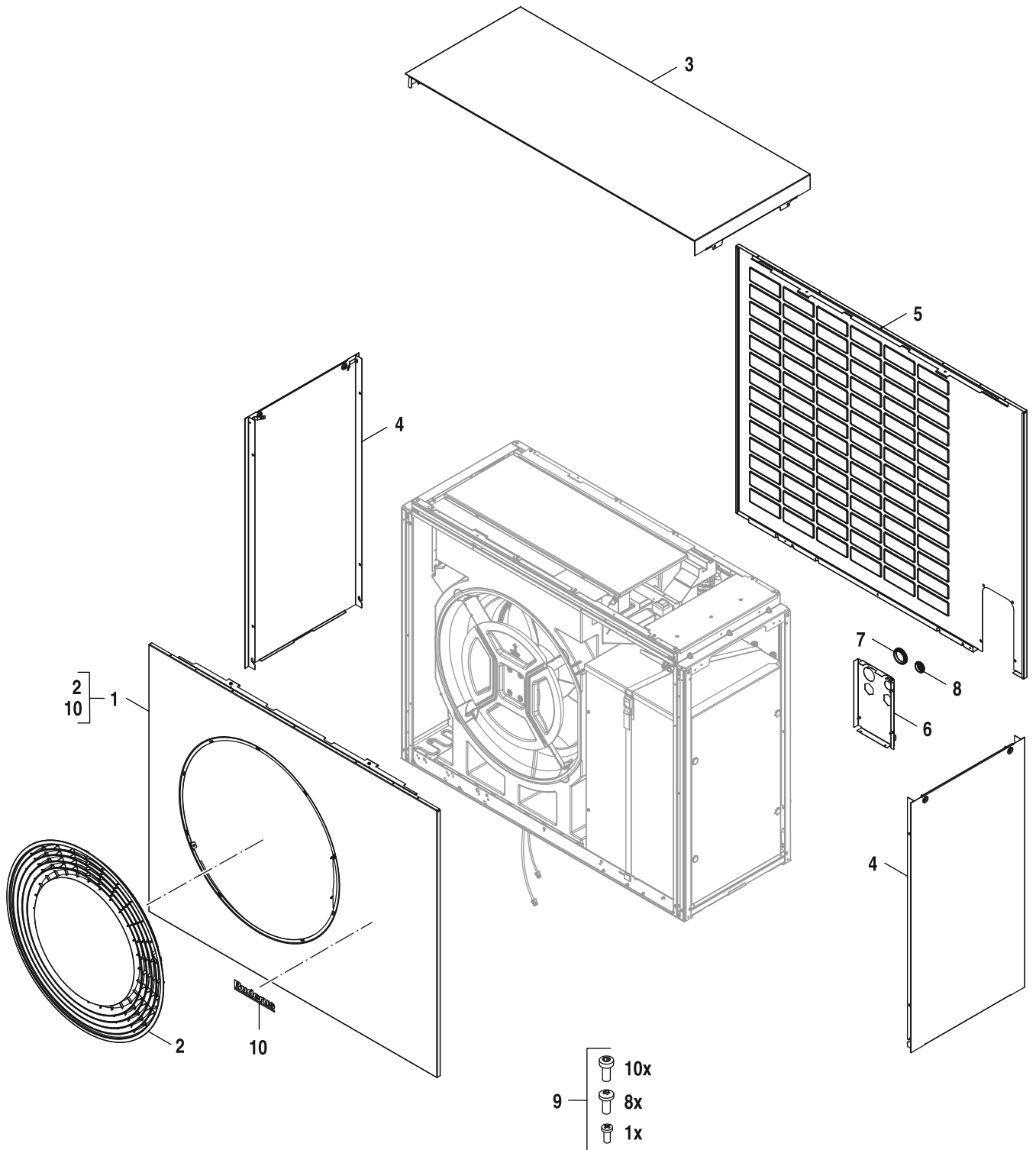

6721905102.ab.RO

1

Verkleidung Bu
Casing Bu
Habillage Bu
Mantello Bu
Toestelmantel Bu

WLW MB-10-12

Pos	Bezeichnung Description Dénomination Descrizioni Benaming		8738215694	8738215695	WLW-10 MB AR	WLW-12 MB AR															Bemerkungen Remarks Remarques Osservazioni Opmerkingen
1	Vorderwand schwarz	8 738 214 516	■	■	■	■															
2	Diffusor schwarz	8 738 214 517	■	■	■	■															
3	Abdeckung oben	8 738 214 510	■	■	■	■															
4	Seitenteil silber	8 738 214 500	■	■	■	■															
5	Rückwand schwarz	8 738 214 509	■	■	■	■															
6	Deckel hinten schwarz	8 738 214 815	■	■	■	■															
7	Kabeldurchführung	8 738 213 889	■	■	■	■															
8	Kabeldurchführung M32	8 738 213 890	■	■	■	■															
9	Montage-Set (Verkleidung)	8 738 213 895	■	■	■	■															
10	Logo Buderus l = 185 mm	8 738 214 964	■	■	■	■															

WLW MB-10-12	Verkleidung Bu Casing Bu Habillage Bu Mantello Bu Toestelmantel Bu	1
---------------------	--	----------

Ersatzteilliste
Spare parts list

Liste des pièces de rechange
Lista parti di ricambio

Onderdelenlijst

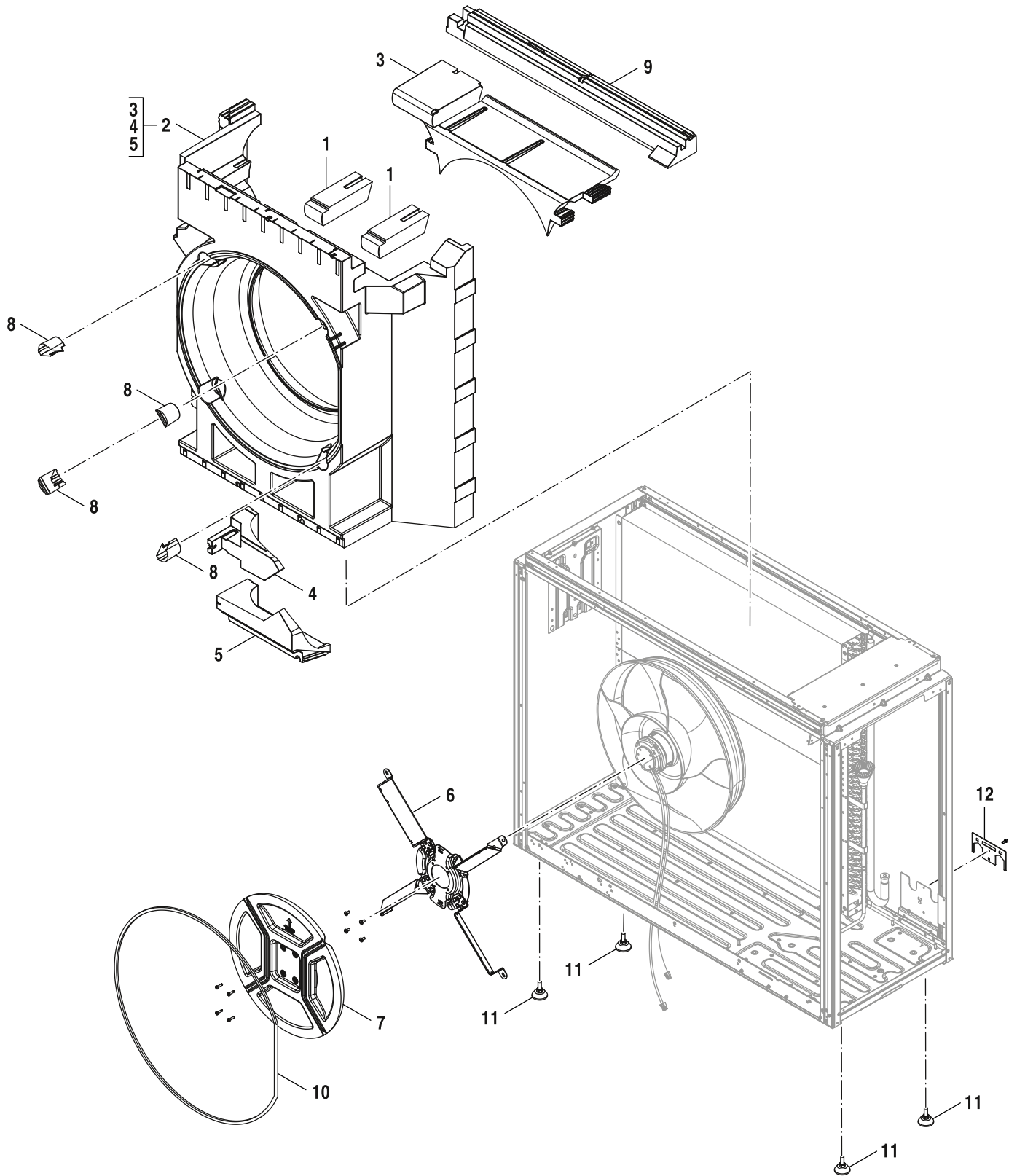

6721905104.ac.RO

2

Gehäuse EPP
Casing EPP
Carter EPP
Involucro EPP
Behuizing EPP

WLW MB-10-12

Pos	Bezeichnung Description Dénomination Descrizioni Benaming		8738215694	8738215695	WLW-10 MB AR	WLW-12 MB AR															Bemerkungen Remarks Remarques Osservazioni Opmerkingen
1	Dämmung EPP	8 738 214 495	■	■	■	■															
2	Dämmung EPP	8 738 214 489	■	■	■	■															
3	Dämmung EPP oben	8 738 214 494	■	■	■	■															
4	Isolierung EPP seitlich	8 738 214 490	■	■	■	■															
5	Isolierung EPP seitlich	8 738 214 491	■	■	■	■															
6	Halter Gebläse	8 738 213 854	■	■	■	■															
7	Isolierung (Difusor)	8 738 214 492	■	■	■	■															
8	Dämmung EPP (Halter Gebläse)	8 738 214 493	■	■	■	■															
9	Dämmung EPP oben Verdampfer	8 738 214 496	■	■	■	■															
10	Dichtung Gehäuse (EPP)	8 738 214 497	■	■	■	■															
11	Stellfuss M10x35	8 748 510 085 0	■	■	■	■															
12	Sicherungsblech	8 738 213 861	■	■	■	■															

WLW MB-10-12	Gehäuse EPP Casing EPP Carter EPP Involucro EPP Behuizing EPP	2
---------------------	---	----------

Ersatzteilliste
Spare parts list

Liste des pièces de rechange
Lista parti di ricambio

Onderdelenlijst

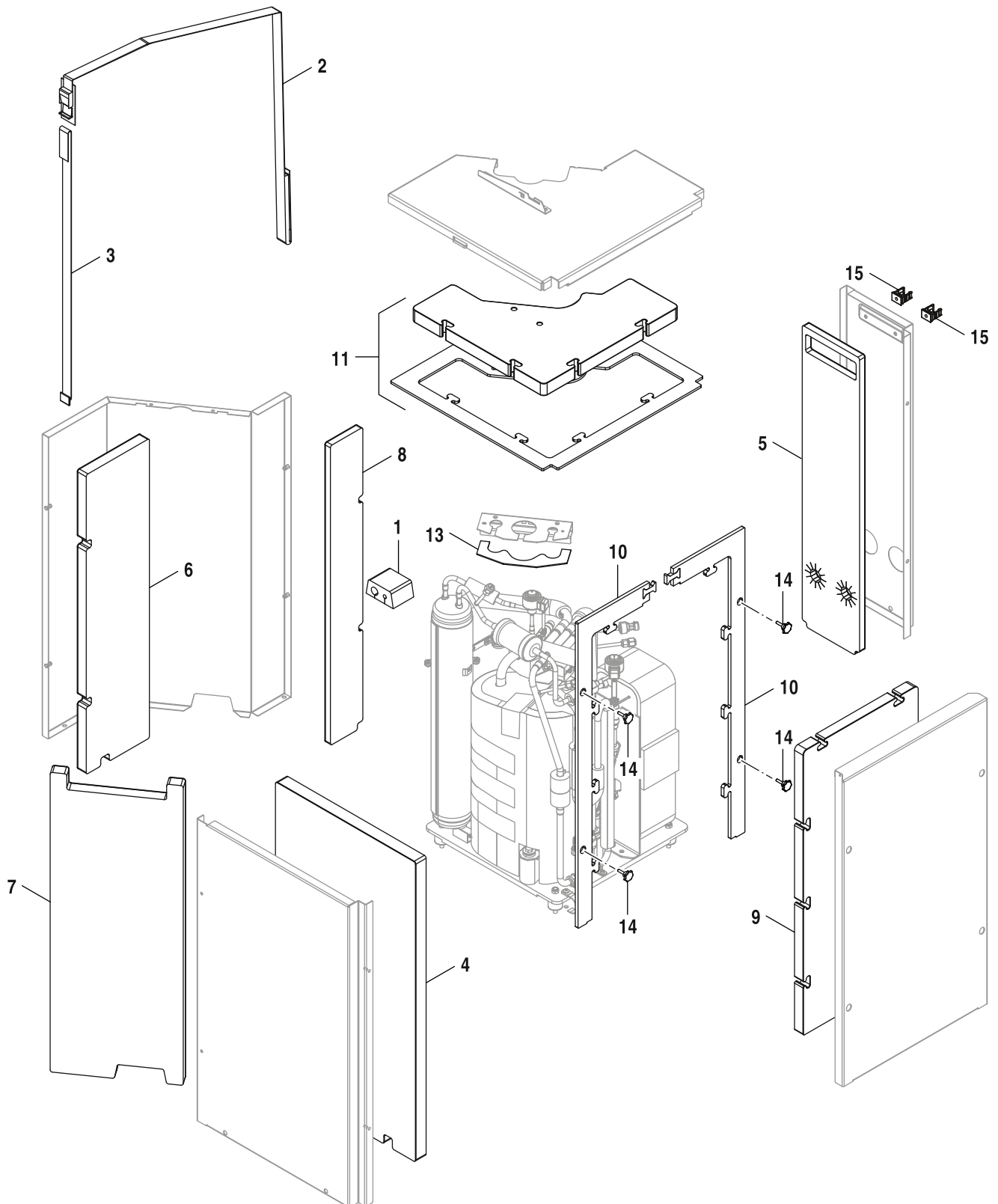

6721905105.ab.RO

3
Dämmung Kältemittelkreis
Insulation Rrefrigerant circuit
Isolation du circuit de réfrigérant
Isolamento del circuito frigorifero
Isolatie van koelcircuit

WLW MB-10-12

Pos	Bezeichnung Description Dénomination Descrizioni Benaming		8738215694	8738215695	WLW-10 MB AR	WLW-12 MB AR															Bemerkungen Remarks Remarques Osservazioni Opmerkingen
1	Dichtung (PE)	8 738 214 529	■	■	■	■															
2	Spannband hinten	8 738 213 864	■	■	■	■															
3	Spannband vorne	8 738 213 865	■	■	■	■															
4	Schalldämmung vorne	8 738 214 522	■	■	■	■															
5	Schalldämmung hinten	8 738 214 523	■	■	■	■															
6	Schalldämmung (185x760)	8 738 214 519	■	■	■	■															
7	Schalldämmung (280x760) links	8 738 214 520	■	■	■	■															
8	Schalldämmung (95x760)	8 738 214 521	■	■	■	■															
9	Schalldämmung (336x720) seitlich	8 738 214 526	■	■	■	■															
10	Isolierung (209.5x773) seitlich	8 738 214 527	■	■	■	■															
11	Schalldämmung oben	8 738 214 524	■	■	■	■															
13	Dichtplatte	8 738 213 876	■	■	■	■															
14	Sterngriff D25 M5x20 (4x)	8 738 213 877	■	■	■	■															
15	Halter Rohr 21,2mm	8 738 211 826	■	■	■	■															

WLW MB-10-12	Dämmung Kältemittelkreis Insulation Rrefrigerant circuit Isolation du circuit de réfrigérant Isolamento del circuito frigorifero Isolatie van koelcircuit	3
---------------------	---	----------

Ersatzteilliste
Spare parts list

Liste des pièces de rechange
Lista parti di ricambio

Onderdelenlijst

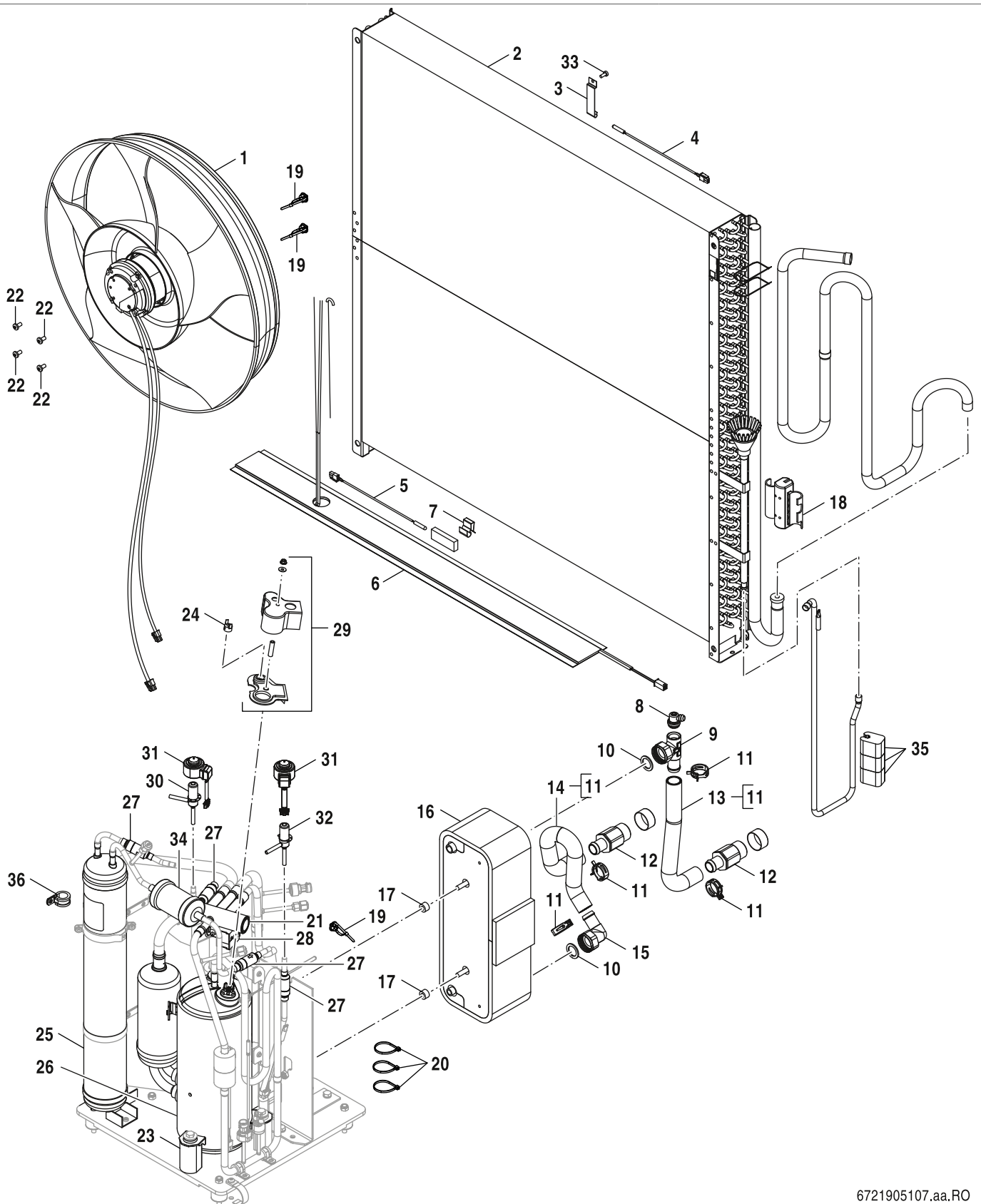

6721905107.aa.RO

4

Kältemittelkreis
Refrigerant circuit
Circuit de réfrigérant
Circuito del refrigerante
Koelmiddelcircuit

WLW MB-10-12

Pos	Bezeichnung Description Dénomination Descrizioni Benaming		8738215694	8738215695	WLW-10 MB AR	WLW-12 MB AR															Bemerkungen Remarks Remarques Osservazioni Opmerkingen
1	Gebläse D500	8 738 214 482	■	■	■																
2	Verdampfer 12kW 5R	8 738 214 471	■	■	■																
3	Klammer (Temperaturfühler)	8 738 213 821	■	■	■																
4	Temperaturfühler NTC 900mm 4,7kOhm	8 738 203 398	■	■	■																
5	Temperaturfühler NTC 1700mm	8 738 213 818	■	■	■																
6	Heizband	8 738 214 481	■	■	■																
7	Klammer	8 738 213 816	■	■	■																
8	Entlüfter	8 717 405 285 0	■	■	■																
9	T-Stück	8 738 213 840	■	■	■																
10	Dichtung 30x21x2 (10x)	8 711 004 362 0	■	■	■																
11	Klammer (Schlauch)	8 738 213 810	■	■	■																
12	Verbindungsstück 1"	8 738 213 837	■	■	■																
13	Schlauch D = 29 mm, l = 245 mm	8 738 213 838	■	■	■																
14	Schlauch D = 29 mm	8 738 213 824	■	■	■																
15	Winkelverschraubung 1"	8 738 213 839	■	■	■																
16	Plattenwärmetauscher 12 kW	8 738 214 467	■	■	■																
17	Abstandshalter Nylon 8,2x16,0x10,0	8 738 206 790	■	■	■																
18	Massedämpfer	8 738 215 025	■	■	■																
19	Kabelbinder	8 738 211 827	■	■	■																
20	Kabelbinder (10x)	8 738 213 836	■	■	■																
21	4-Wege-Ventil	8 738 213 829	■	■	■																
22	Schraube M6x12 (4x)	8 738 213 899	■	■	■																
23	Schwingungsdämpfer	8 738 213 844	■	■	■																
24	Thermosicherung (Kompressor)	8 738 213 846	■	■	■																
25	Behälter Kältemittel 1,5 L	8 738 214 470	■	■	■																
26	Kompressor Highly WHP013300	8 738 214 465	■	■	■																
27	Filter (Kältemittel)	8 738 211 554	■	■	■																
28	Spule	8 738 213 825	■	■	■																
29	Abdeckung (Kompressor-Set)	8 738 213 845	■	■	■																
30	Expansionsventil	8 738 214 468	■	■	■																
31	Spule	8 738 213 826	■	■	■																
32	Expansionsventil	8 738 214 469	■	■	■																
33	Schraube M5x12 (5x)	8 738 213 622	■	■	■																
34	Trockenfilter	8 733 702 983	■	■	■																
35	Massedämpfer 9.52 x 32.5mm	8 738 215 594	■	■	■																
36	Schelle 20/12 mm (2x)	8 738 215 593	■	■	■																

WLW MB-10-12

Kältemittelkreis
 Rrefrigerant circuit
 Circuit de réfrigérant
 Circuito del refrigerante
 Koelmiddelcircuit

4

Ersatzteilliste
Spare parts list

Liste des pièces de rechange
Lista parti di ricambio

Onderdelenlijst

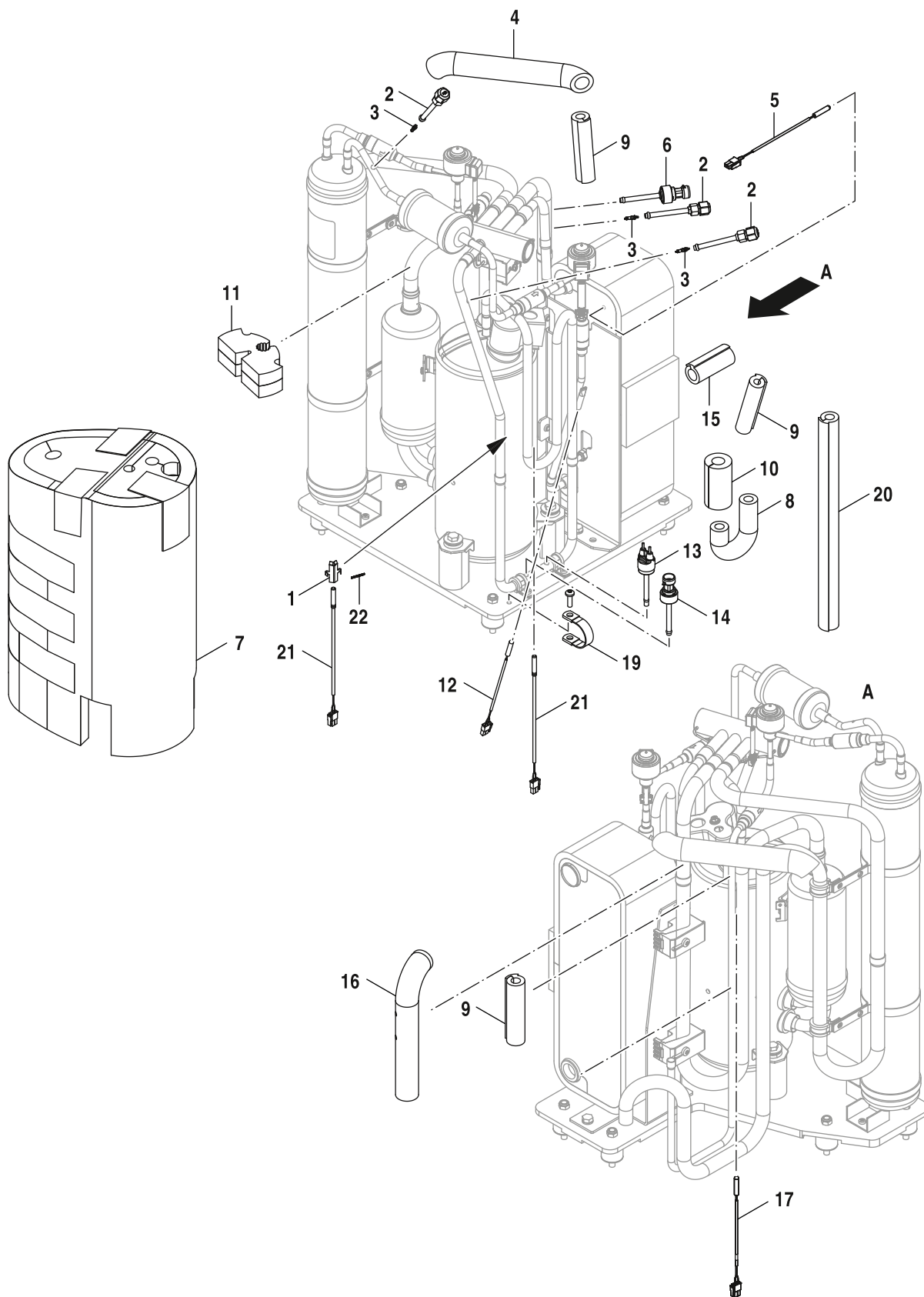

6721905106.aa.RO

5

Fühler und Isolierungen
Sensors and insulations
Sondes et isolations
Sensori e isolamento
Sensoren en isolatie

WLW MB-10-12

Pos	Bezeichnung Description Dénomination Descrizioni Benaming		8738215694	8738215695	WLW-10 MB AR	WLW-12 MB AR															Bemerkungen Remarks Remarques Osservazioni Opmerkingen
1	Halterung	8 738 213 832	■	■	■	■															
2	Ventil Schrader 5/16" ASM	8 738 211 579	■	■	■	■															
3	Einsatz (Ventil)	8 738 211 578	■	■	■	■															
4	Isolierung 245 mm	8 738 214 473	■	■	■	■															
5	Temperaturfühler NTC10 1000mm R40 molex	8 738 206 065	■	■	■	■															
6	Druckfühler	8 738 213 813	■	■	■	■															
7	Isolierung Kompressor	8 738 214 466	■	■	■	■															
8	Isolierung 155 mm	8 738 214 475	■	■	■	■															
9	Isolierung 100 mm	8 738 215 595	■	■	■	■															
10	Isolierung (Temperaturfühler)	8 738 211 506	■	■	■	■															
11	Massedämpfer 19.05 x 19.8mm	8 738 215 592	■	■	■	■															
12	Temperaturfühler 200 mm, 10 kOhm	8 733 703 181	■	■	■	■															
13	Druckschalter	8 738 213 811	■	■	■	■															
14	Druckfühler	8 738 213 848	■	■	■	■															
15	Isolierung 70 mm	8 738 214 476	■	■	■	■															
16	Isolierung 230 mm	8 738 214 477	■	■	■	■															
17	Temperaturfühler 200mm, 4,7 kOhm	8 733 703 183	■	■	■	■															
19	Erdungsband	8 738 213 834	■	■	■	■															
20	Isolierung 350 mm	8 738 214 474	■	■	■	■															
21	Temperaturfühler 1000 mm R80	8 738 207 622	■	■	■	■															
22	Haltefeder	8 738 213 833	■	■	■	■															

WLW MB-10-12	Fühler und Isolierungen Sensors and insulations Sondes et isolations Sensori e isolamento Sensoren en isolatie	5
---------------------	--	----------

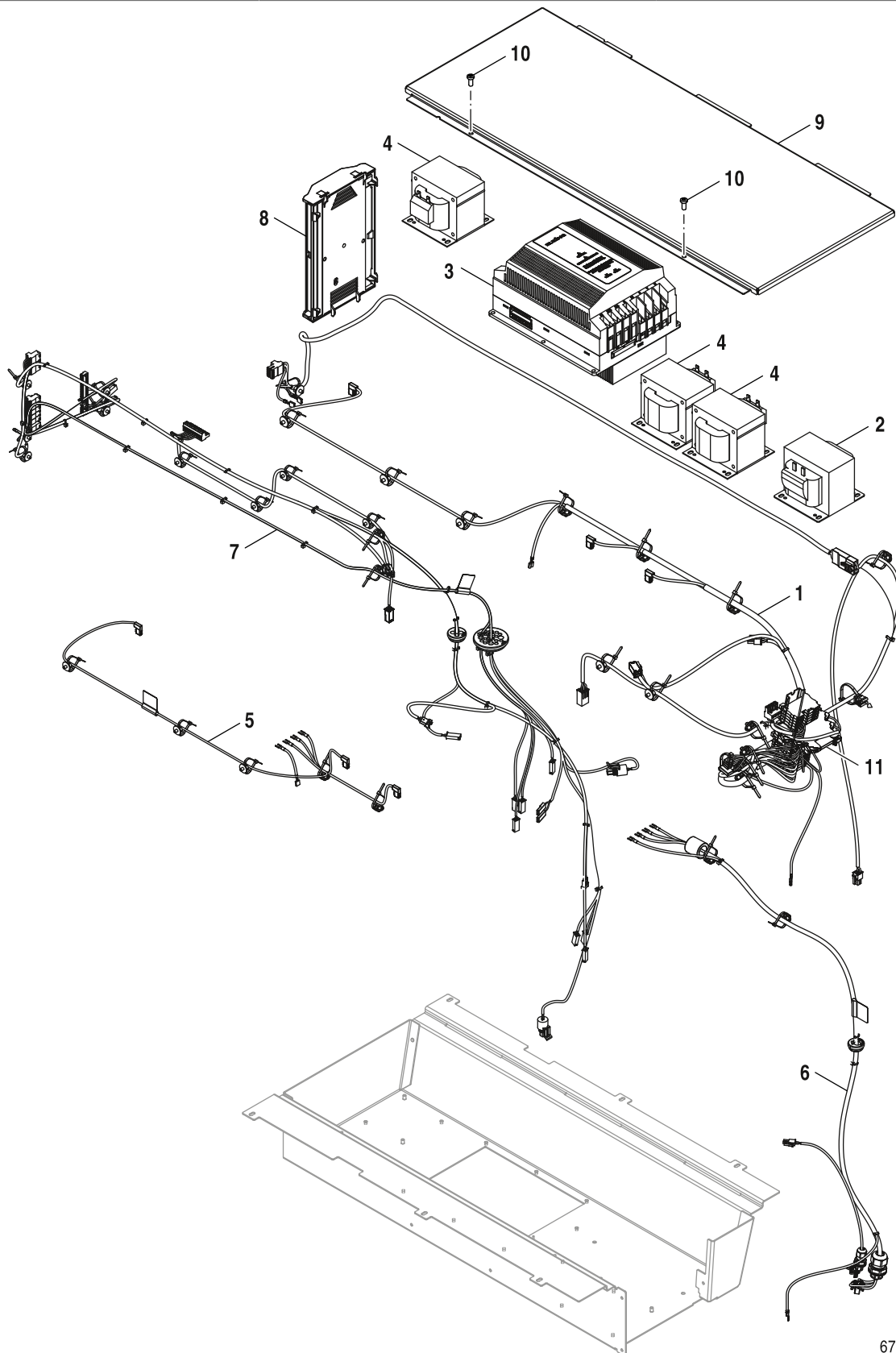

6721905103.ab.RO

6
Regelung
Control
Régulation
Termoregolazione
Regeling

WLW MB-10-12

Pos	Bezeichnung Description Dénomination Descrizioni Benaming		8738215694	8738215695	WLW-10 MB AR	WLW-12 MB AR															Bemerkungen Remarks Remarques Osservazioni Opmerkingen
1	Kabelbaum IWI 12kW	8 738 214 483	■	■	■	■															
2	Drosselspule C02W25B00-01	8 738 215 596	■	■	■	■															
3	Wechselrichter	8 738 214 487	■	■	■	■															
4	Drosselspule	8 738 215 024	■	■	■	■															
5	Kabelbaum EL-box 12kW	8 738 214 484	■	■	■	■															
6	Kabelbaum (Kompressor) 12 kW	8 738 214 485	■	■	■	■															
7	Kabelbaum LV 12kW	8 738 214 486	■	■	■	■															
8	I/O Modul XCU-SRH V9.6.1 Uni 10	8 738 216 058	■	■																	
8	I/O Modul XCU-SRH V9.6.1 Uni 12	8 738 216 059		■	■																
9	Abdeckung	8 738 214 518	■	■	■	■															
10	Schraube M5x12 (5x)	8 738 213 622	■	■	■	■															
11	Relais REL-MR-24DC/21	8 738 214 607	■	■	■	■															

WLW MB-10-12	Regelung Control Régulation Termoregolazione Regeling	6
---------------------	---	----------

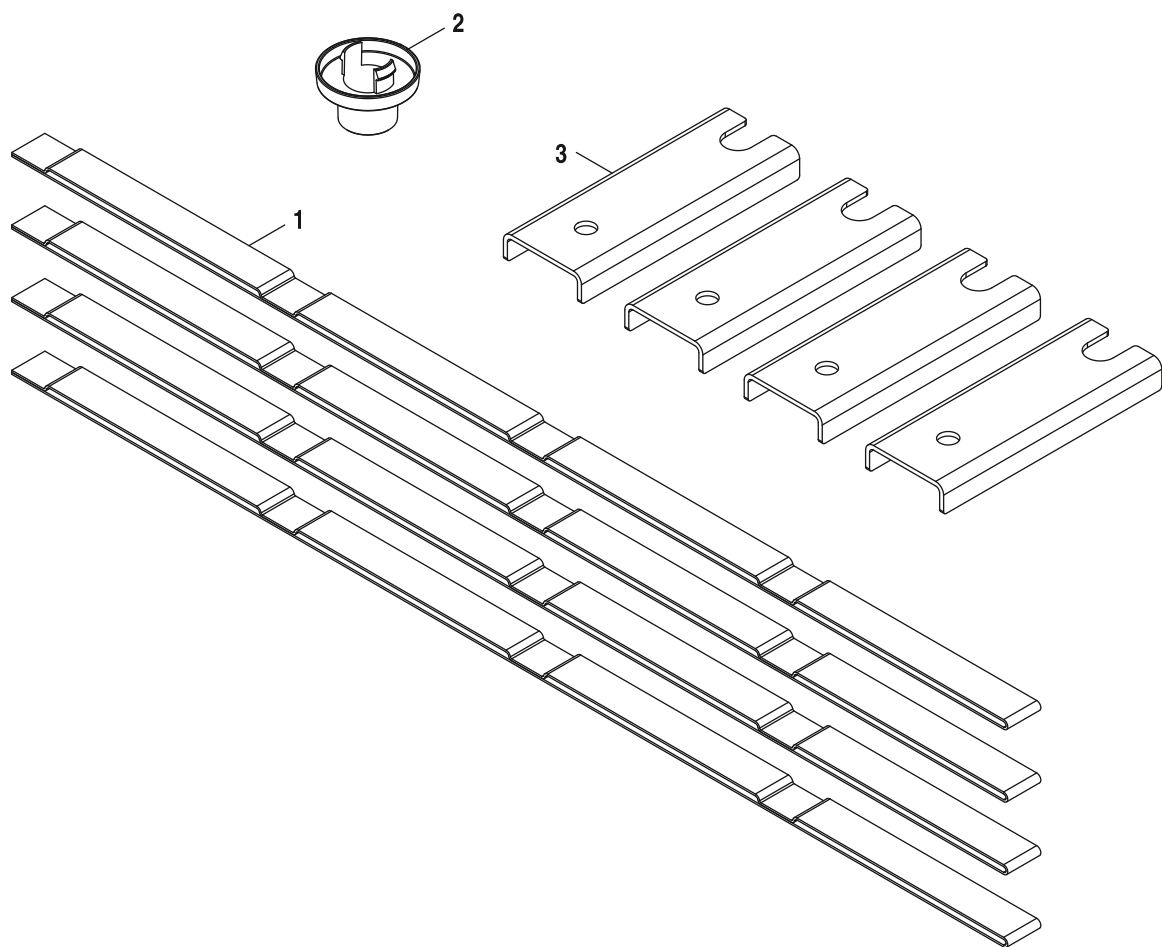

6721905324.aa.RO

7

Zubehör
Accessories
Accessoire
Accessori
Accessoires

WLW MB-10-12

Pos	Bezeichnung Description Dénomination Descrizioni Benaming		8738215694	8738215695	WLW-10 MB AR	WLW-12 MB AR														Bemerkungen Remarks Remarques Osservazioni Opmerkingen
1	Transportgurt L = 753 mm	8 738 213 862	■	■	■	■														
2	Kondensatablaufstutzen	8 738 213 860	■	■	■	■														
3	Halterung (4x)	8 738 215 631	■	■	■	■														

WLW MB-10-12	Zubehör Accessories Accessoire Accessori Accessoires	7
---------------------	--	----------

Übersetzungsliste		Liste des traductions		Vertalinglijst	
List of translations		Traduzione delle descrizioni			
Pos	Description	Description	Descrizione	Beschrijving	
1	Element of construction	Groupe d'assemblage	Gruppo di montaggio	Montage groep	
1	Front panel black	Panneau avant noir	Pannello anteriore nero	Voorwand zwart	
2	Diffuser black	Diffuseur noir	Diffusore nero	Diffuser zwart	
3	Cover top	Revêtement haut	Pannello protettivo sopra	Afdekking Boven	
4	Side panel silver	Panneau latéral argent	Pannello laterale argentato	Zijpaneel zilver	
5	Backpanel black	Panneau arrière noir	Copertura posteriore nero	Achterwand zwart	
6	Cover back black	Couvercle arrière noir	Coperchio posteriore nero	Deksel Achter zwart	
7	Cable feedthrough	Passe-câbles	Prensa cable	Doorvoertule	
8	Cable feedthrough M32	Passe-câbles M32	Prensa cable M32	Doorvoertule M32	
9	Installation set (Casing)	Kit De Montage Pour Habillage	Set di fissaggio (Mantello)	Montageset (Toestelmantel)	
10	Logo Buderus I = 185 mm	Logo Buderus I = 185 mm	Logo Buderus I = 185 mm	Logo Buderus I = 185 mm	
2	Element of construction	Groupe d'assemblage	Gruppo di montaggio	Montage groep	
1	Insulation EPP shelf insert	Isolation EPP	Isolamento EPP	Isolatie EPP	
2	Insulation EPP air channel	Isolation EPP	Isolamento EPP	Isolatie EPP	
3	Insulation EPP top	Isolation EPP haut	Isolamento EPP sopra	Isolatie EPP Boven	
4	Insulation EPP side	Isolation EPP côté	Isolamento elettrico EPP laterale	Isolatie EPP zijkant	
5	Insulation EPP side	Isolation EPP côté	Isolamento elettrico EPP laterale	Isolatie EPP zijkant	
6	Holder Fan	Support De Ventilateur	Supporto Ventilatore	Houder Ventilator	
7	Insulation (Difusor)	Isolation (Difusor)	Isolamento (Difusor)	Isolatie (Difusor)	
8	Insulation EPP (cover fan holder)	Isolation EPP	Isolamento EPP	Isolatie EPP	
9	Insulation EPP top Evaporator	Isolation EPP haut Évaporateur	Isolamento EPP sopra Evaporatore	Isolatie EPP Boven Verdamer	
10	Gasket Casing (EPP)	Joint Carter (EPP)	Guarnizione Involucro (EPP)	Pakking Behuizing (EPP)	
11	Rubber foot M10x35	PIED M10x35	Vite	Stelvoet M10x35	
12	Locking plate	Tôle de sécurité	Lamiera di sicurezza	Borgplaat	
3	Element of construction	Groupe d'assemblage	Gruppo di montaggio	Montage groep	
1	Gasket (PE)	Joint (PE)	Guarnizione (PE)	Pakking (PE)	
2	Fixing strap back	Sangle arrière	Fascetta di serraggio posteriore	Spanband Achter	
3	Fixing strap front	Sangle avant	Fascetta di serraggio anteriore	Spanband Voor	
4	Sound insulation front	Isolation acoustique avant	Isolamento acustico anteriore	Geluidsdemping Voor	
5	Sound insulation back	Isolation acoustique arrière	Isolamento acustico posteriore	Geluidsdemping Achter	
6	Sound insulation (185x760)	Isolation acoustique (185x760)	Isolamento acustico (185x760)	Geluidsdemping (185x760)	
7	Sound insulation (280x760) left	Isolation acoustique (280x760) gauche	Isolamento acustico (280x760) sinistra	Geluidsdemping (280x760) Links	

Übersetzungsliste		Liste des traductions		Vertalinglijst	
List of translations		Traduzione delle descrizioni			
Pos	Description	Description	Descrizione	Beschrijving	
8	Sound insulation (95x760)	Isolation acoustique (95x760)	Isolamento acustico (95x760)	Geluidsdemping (95x760)	
9	Sound insulation (336x720) side	Isolation acoustique (336x720) côté	Isolamento acustico (336x720) laterale	Geluidsdemping (336x720) zijkant	
10	Insulation (209.5x773) side	Isolation (209.5x773) côté	Isolamento (209.5x773) laterale	Isolatie (209.5x773) zijkant	
11	Sound insulation top	Isolation acoustique haut	Insonorización arriba	Isolamento acustico sopra	
13	Sealing plate	Plaque de scellement	Piastra di tenuta	Afdichtplaat	
14	Handle M5x20, Head D25 (4x)	Poignée M5x20, Tête D25 (4x)	Maniglia M5x20, testa D25 (4x)	Handgreep M5x20, kop D25 (4x)	
15	Holder pipe 21,2mm	Support Tube 21,2mm	Supporto Tubo 21,2mm	Houder Buis 21,2mm	
4	Element of construction	Groupe d'assemblage	Gruppo di montaggio	Montage groep	
1	Fan D500	Ventilateur D500	Ventilatore D500	Ventilator D500	
2	Evaporator 12kW 5R	Évaporateur 12kW 5R	Evaporatore 12kW 5R	Verdamper 12kW 5R	
3	Clip (Temperature sensor)	Clip Pour Sonde De Température	Clip a innesto (Sonda di temperatura)	Klem (Temperatuursensor)	
4	Temperature sensor NTC 900mm 4,7kOhm	Sonde de température NTC 900mm 4,7kOhm	Sensore sicurezza di temperatura NTC 900	Temperatuursensor NTC 900mm 4,7kOhm	
5	Temperature sensor NTC 1700mm	Sonde de température NTC 1700mm	Sonda di temperatura NTC 1700mm	Temperatuursensor NTC 1700mm	
6	Heater (drip tray)	Ruban chauffant	Nastro riscaldante	Verwarmingslint	
7	Clip	Clip	Clip a innesto	Klem	
8	Air vent	Soupape de ventilation	Disaeratore	Ontluchter	
9	Tee	Raccord en T	Raccordo a T	T-stuk	
10	Gasket 1" 30x21x2 (10x)	Joint pompes AWM 1" 30x21x2 (10x)	Guarnizione 30x21x2 (10x)	pakking 30x21x2 (10x)	
11	Clip (Hose)	Clip Pour Tube flexible	Clip a innesto (Tubo flessibile)	Klem (Slang)	
12	Connection piece 1"	Pièce de raccordement 1"	Elemento di collegamento 1"	Rookgasverbindingsstuk 1"	
13	Hose D = 29 mm, l = 245 mm	Tuyau Souple Diamètre De 29mm, l = 245mm	Tubo flessibile D = 29 mm, l = 245 mm	Slang D = 29 mm, l = 245 mm	
14	Hose D = 29 mm	Tuyau Souple Diamètre De 29mm	Tubo flessibile D = 29 mm	Slang D = 29 mm	
15	Elbow fitting 1"	Raccord à vis coudé 1"	Raccordo filettato angolare 1"	Haakse schroefverbinding 1"	
16	Plate heat exchanger 12kW	Échangeur à plaques 12 kW	Scambiatore di calore a piastre 12 kW	Platenwisselaar 12 kW	
17	Spacer Nylon 8,2x16,0x10,0	Entretoise Nylon 8,2x16,0x10,0mm	Distanziale Nylon 8,2x16,0x10,0	Afstandhouder Nylon 8,2x16,0x10,0	
18	Mass damper	Amortisseur de masse	Ammortizzatore di massa	Massademper	
19	Cable tie	Attache de câbles	Fascetta stringicavi	Kabelbinder	
20	Cable tie (10x)	Attache de câbles (10x)	Fascetta stringicavi (10x)	Kabelbinder (10x)	
21	4-way valve	Vanne 4 voies	Organo 4 vie	4-wegklep	
22	Screw M6x12 (4x)	Vis M6x12 (4x)	Bullone,vite M6x12 (4x)	Schroef M6x12 (4x)	
23	Anti-vibration coupling	Plot antivibratile	Ammortizzatore di vibrazioni	Trillingsdemper	
24	Thermal cut out (Compressor)	Disjoncteur Thermique Du Compresseur	Disgiuntore termico (Compressore)	Thermische zekering (Compressor)	

Übersetzungsliste		Liste des traductions		Vertalinglijst	
List of translations		Traduzione delle descrizioni			
Pos	Description	Description	Descrizione	Beschrijving	
25	Accumulator Refrigerant 2,5 L	Ballon de stockage 1,5 L	Recipiente 1,5 L	Reservoir 1,5 L	
26	Compressor Highly WHP013300	Compresseur Highly WHP013300	Compressore Highly WHP013300	Compressor Highly WHP013300	
27	Filter (Refrigerant)	Filtre Pour Réfrigérant	Filtro (Refrigerante)	Filter (Koudemiddel)	
28	Coil	Bobine	Bobina	Spoel	
29	Cover (Compressor kit)	Couvercle De Jeu Compresseur	Copertura (Kit compressore)	Afdekking (Compressor-set)	
30	Expansion valve	Détendeur	Valvola di espansione	Expansieventiel	
31	Coil	Bobine	Bobina	Spoel	
32	Expansion valve	Détendeur	Valvola di espansione	Expansieventiel	
33	Screw M5x12 (5x)	Vis M5x12 (5x)	Vite M5x12 (5x)	Schroef M5x12 (5x)	
34	Dry filter	Filtre sec ODU	Filtro a secco	Droogfilter	
35	Mass damper 9.52 x 32.5mm	Amortisseur de masse 9.52 x 32.5mm	Ammortizzatore di massa 9.52 x 32.5mm	Massademper 9.52 x 32.5mm	
36	Pipe Clamp 20/12 mm (2x)	Collier 20/12 mm (2x)	Morsetto 20/12 mm (2x)	Klem 20/12 mm (2x)	
5	Element of construction	Groupe d'assemblage	Gruppo di montaggio	Montage groep	
1	Bracket	Support	Supporto	Beugel	
2	Vavle Schrader ASM	Vanne Schrader 5/16" ASM	Valvola Schrader 5/16" ASM	Ventiel Schrader 5/16" ASM	
3	Cartridge (Valve)	Cartouche De Vanne	Cartuccia (Valvola)	Houder (Ventiel)	
4	Insulation 245 mm	Isolation 245 mm	Coibentazione 245 mm	Isolatie 245 mm	
5	Temperature sensor NTC10 1000mm R40 mol	Sonde de température NTC 1000mm R40 mole	Sensore di temperatura NTC10 1000mm R40	Temperatuursensor NTC10 1000mm R40 molex	
6	Pressure sensor	Capteur de pression	Sensore di pressione	Druksensor	
7	Insulation compressor	Isolation Compresseur	Isolamento Compressore	Isolatie Compressor	
8	Insulation 155 mm	Isolation 155 mm	Coibentazione 155 mm	Isolatie 155 mm	
9	Insulation 100 mm	Isolation 100 mm	Coibentazione 100 mm	Isolatie 100 mm	
10	Insulation (Temperature sensor)	Isolation De Sonde De Température	Coibentazione (Sonda di temperatura)	Isolatie (Temperatuursensor)	
11	Mass damper 19.05 x 19.8mm	Amortisseur de masse 19.05 x 19.8mm	Ammortizzatore di massa 19.05 x 19.8mm	Massademper 19.05 x 19.8mm	
12	Temperature sensor 200 mm, 10 kOhm	Sonde de température 200mm, 10 kOhm	Sensore di temperatura 200 mm	Temperatuursensor 200 mm, 10 kOhm	
13	Pressure switch	Interrupteur pression	Pressostato	Drukverschilschakelaar	
14	Pressure sensor	Capteur de pression	Sensore di pressione	Druksensor	
15	Insulation 70 mm	Isolation 70 mm	Coibentazione 70 mm	Isolatie 70 mm	
16	Insulation 230 mm	Isolation 230 mm	Coibentazione 230 mm	Isolatie 230 mm	
17	Temperature sensor 200mm, 4,7 kOhm	Sonde de température 200mm, 4,7 kOhm	Sensore di temperatura 200mm,	Temperatuursensor 200mm, 4,7 kOhm	
19	Earthing strap	Mise à la terre	Messa a terra	Aardclip	
20	Insulation Pipe Compressor_4WV_2	Isolation 350 mm	Coibentazione 350 mm	Isolatie 350 mm	

Übersetzungsliste
List of translations

Liste des traductions
Traduzione delle descrizioni

Vertalinglijst

Pos	Description	Description	Descrizione	Beschrijving	
21	Temperature sensor 1000 mm R80	Sonde de température 1000mm R80	Sonda di temperatura 1000mm R80	Temperatuursensor 1000mm R80	
22	Clip	Epingle	Molla di ritenzione	Borgveer	
6	Element of construction	Groupe d'assemblage	Gruppo di montaggio	Montage groep	
1	Cable harness IWI 12kW	Mazo de cables IWI 12kW	Faisceau de câbles IWI 12kW	Cablaggio IWI 12kW	
2	Choke C02W25B00-01	Serpentin C02W25B00-01	Bobina C02W25B00-01	Spoel C02W25B00-01	
3	Inverter	Onduleur	Inverter	Omvormer	
4	Choke	Serpentin	Bobina	Spoel	
5	Cable harness EL-box 12kW	Mazo de cables EL-box 12kW	Faisceau de câbles EL-box 12kW	Cablaggio EL-box 12kW	
6	Cable harness (Compressor) 12 kW	Faisceau de câbles (Compresseur) 12 kW	Cablaggio (Compressore) 12 kW	Kabelboom (Compressor) 12 kW	
7	Cable harness LV 12kW	Faisceau de câbles LV 12kW	Cablaggio LV 12kW	Kabelboom LV 12kW	
8	I/O Module XCU-SRH V9.6.1 Uni 10	Module d'E-S XCU-SRH V9.6.1 Uni 10	Modulo I/O XCU-SRH V9.6.1 Uni 10	I/O-module XCU-SRH V9.6.1 Uni 10	
8	I/O Module XCU-SRH V9.6.1 Uni 12	Module d'E-S XCU-SRH V9.6.1 Uni 12	Modulo I/O XCU-SRH V9.6.1 Uni 12	I/O-module XCU-SRH V9.6.1 Uni 12	
9	Cover	Couvercle	Copertura	Afdekking	
10	Screw M5x12 (5x)	Vis M5x12 (5x)	Vite M5x12 (5x)	Schroef M5x12 (5x)	
11	Relay REL-MR-24DC/21	Relais REL-MR-24DC/21	Relè REL-MR-24DC/21	Relais REL-MR-24DC/21	
7	Element of construction	Groupe d'assemblage	Gruppo di montaggio	Montage groep	
1	Belt lifting L = 753 mm	Sangle De Levage Longueur De 753mm	Imbragatura L = 753 mm	Sling L = 753 mm	
2	Condensate drain socket	Prise d'évacuation des condensats	Presa per scarico condensa	Condensaat aftapplug	
3	Bracket (4x)	Support (4x)	Supporto (4x)	Beugel (4x)	

Gerätetypen Types of appliances		Types de chaudières Tipo apparecchi		Toesteltypen
Gerät Appliance Chaudière Apparecchio Toestel		Land Country Pays Paese Land		Bemerkungen Remarks Remarques Osservazioni Opmerkingen
WLW-10 MB AR	8 738 213 472	AT,BE,CH,DE,IT,LU,PL		
WLW-12 MB AR	8 738 213 473	AT,BE,CH,DE,IT,LU,PL		
WLW-10 MB AR	8 738 215 694	CZ,EE,LT,LV,PL,SK		
WLW-12 MB AR	8 738 215 695	CZ,EE,LT,LV,PL,SK		

Bosch Thermotechnik GmbH
Sophienstr. 30-32
D-35576 Wetzlar / Germany

Buderus