

B 500 ER - B 1300-6 ER

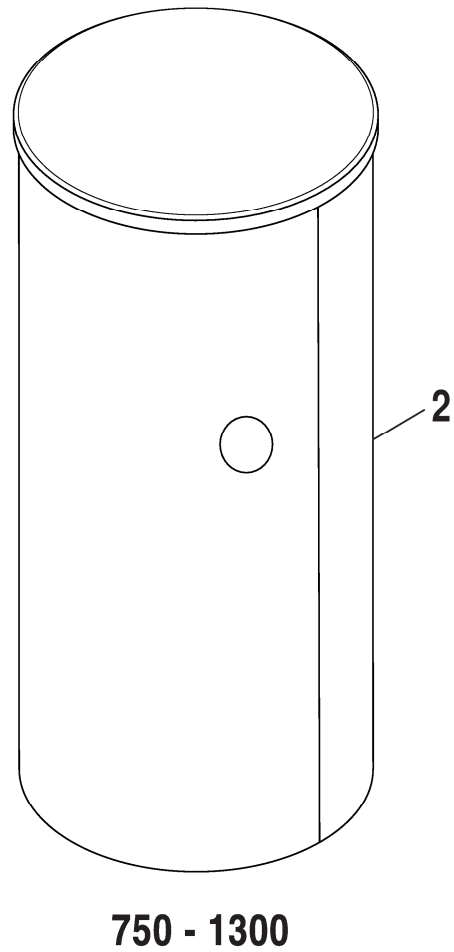

8738893757.aa.RO

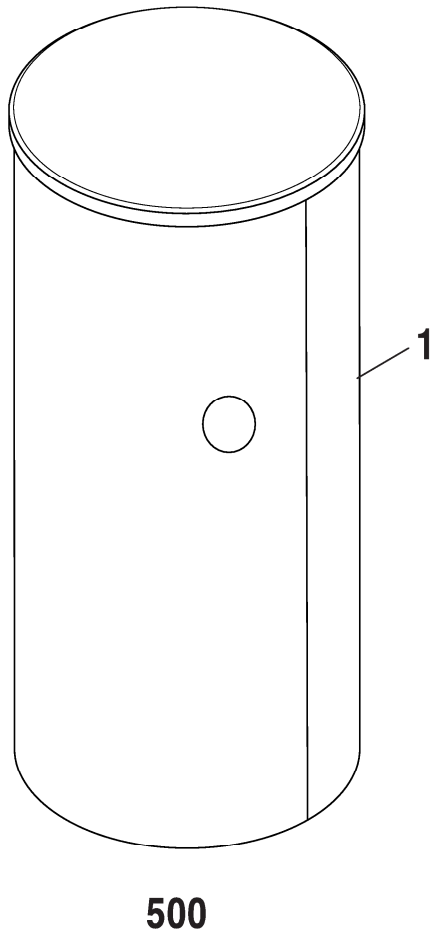

BOSCH

[de] Wichtige Hinweise zur Installation/Montage

Die Installation/Montage muss durch eine für die Arbeiten zugelassene Fachkraft unter Beachtung der geltenden Vorschriften erfolgen.

[en] Important notes on installation/assembly

The installation/assembly must be carried out by a professional who is authorised to do the work, and with due regard to the relevant regulations.

[fr] Instructions importantes pour l'installation/le montage

L'installation/le montage doit être effectué(e) par un spécialiste qualifié pour les opérations concernées et dans le respect des prescriptions applicables.

[bg] Важни указания във връзка с инсталацията/монтажа

Инсталацията/монтажът трябва да се извършва от лицензиран за работите специалист в съответствие с приложимите разпоредби.

[cs] Důležité pokyny k instalaci/montáži

Instalaci/montáž musí při dodržení platných předpisů provést odborný pracovník s příslušným oprávněním pro tyto práce.

[da] Vigtige anvisninger til installationen/monteringen

Installationen/monteringen skal foretages af en godkendt installatør under overholdelse af de gældende forskrifter.

[el] Σημαντικές υποδείξεις για την εγκατάσταση/συναρμολόγηση

Η εγκατάσταση/συναρμολόγηση πρέπει να πραγματοποιείται από εξουσιοδοτημένο για τις εργασίες αυτές τεχνικό προσωπικό, το οποίο θα πρέπει να φροντίζει ώστε να τηρούνται οι ισχύουσες διατάξεις.

[es] Indicaciones importantes para instalación/montaje

La instalación/el montaje lo debe realizar personal especializado autorizado para los trabajos, respetando las prescripciones vigentes.

[et] Olulised juhised paigaldamiseks/montaažiks

Paigaldamist/montaaži tohib läbi viia selleks volitusi omav spetsialist, arvestades kehtivaid nõudeid.

[fi] Belangrijke aanwijzingen betreffende de installatie/montage

De installatie/montage moet worden uitgevoerd door een voor de werkzaamheden geautoriseerde installateur. Hij moet rekening houden met de geldende voorschriften.

[fi] Tärkeitä asennus- ja kokoonpano-ohjeita

Näihin töihin hyväksytyn ammattiasentajan pitää suorittaa asennus- ja kokoonpanotyöt voimassa olevien määräysten mukaisesti.

[hu] Fontos tudnivalók az installáláshoz/szereléshez

Az installálást/szerelést egy, a munkákra felhatalmazott szakembernek kell végeznie, az érvényes előírások figyelembevételével.

[it] Avvertenze importanti per l'installazione/il montaggio

L'installazione/il montaggio deve aver luogo ad opera di una ditta specializzata ed autorizzata in osservanza delle disposizioni vigenti.

[he] מניפולציות חיוניות לביצוע התקנת/הרכבת המוצר

התקנת/הרכבת המוצר חייבת להיעשות על ידי מומחה מוסמך, המעריך את התנאים ומוקדם מראש, ומוקדם מראש, ומוקדם מראש, ומוקדם מראש.

[lt] Svarbios instaliavimo ir (arba) montavimo nuorodos

Instaliuoti ir montuoti, laikantis galiojančių taisyklių, leidžiama kvalifikuotiems specialistams, kurie buvo įgalioti šioms darbams atlikti.

[lv] Svarīgi norādījumi par iekārtas uzstādīšanu / montāžu

Iekārtas uzstādīšanu/montāžu ir jāveic specializētam sertificētam speciālistam, ievērojot spēkā esošos noteikumus.

[nl] Belangrijke aanwijzingen betreffende de installatie/montage

De installatie/montage moet worden uitgevoerd door een voor de werkzaamheden geautoriseerde installateur rekening houdend met de geldende voorschriften.

[no] Viktig informasjon om installasjon/montering

Installasjonen/monteringen skal gjennomføres av autoriserte installatører, og gjeldende forskrifter skal følges.

[pl] Ważne wskazówki dotyczące instalacji/montażu

Instalacja /montaż muszą być wykonane przez uprawnionego do tego rodzaju prac specjalistę przy zachowaniu obowiązujących przepisów.

[pt] Indicações importantes relativas à instalação/montagem

A instalação/montagem deve ser efetuada por um técnico especializado com qualificações para estes trabalhos, tendo em atenção os regulamentos em vigor.

[ro] Indicații importante privind instalarea/montajul

Instalarea/montajul trebuie realizate de către un specialist autorizat pentru lucrările respective, respectându-se prescripțiile valabile.

[ru] Важные указания по подключению/монтажу

Подключение/монтаж должны выполнять специалисты, имеющие допуск к выполнению таких работ, при соблюдении действующих норм и правил.

[sk] Dôležité pokyny týkajúce sa inštalácie/montáže

Inštaláciu/montáž musí realizovať odborník s oprávnením na výkon týchto prác, pričom musí dodržiavať platné predpisy.

[sl] Pomembni napotki za nameštitev/montažo

Nameštitev/montažo mora izvesti strokovnjak, pristojen za tovrstna dela, ob upošte vanju veljavnih predpisov.

[sr] Važna uputstva za ugradnju i montažu

Ugradnju i montažu moraju da obave samo stručna lica ovlašćena za izvođenje takvih radova koja će poštovati važeće propise.

[sv] Viktiga anvisningar för installation/montering

Installationen/monteringen måste utföras av en behörig och fackkunnig person enligt gällande föreskrifter.

[tr] Kurulum/Montaj ile ilgili önemli uyarılar

Kurulum/Montaj çalışmaları sadece yetkili bayiler tarafından aşağıda belirtilen talimatlar dikkate alınarak yapılmalıdır.

[uk] Важливі вказівки щодо установки/монтажу

Установку/монтаж мають здійснювати фахівці, що мають дозвіл на проведення цих робіт, із дотримання чинних приписів.

[zh] 安装方面的重要提示

必须由受到许可承担该项工作的专业人员遵照相关法规进行安装。





[ar] ملاحظات هامة للتثبيت/التجميع
يجب أن يتم التثبيت/التجميع من قبل متخصص مصرح له بالعمل، مع مراعاة اللوائح السارية.

[fa] تکرار مهم درباره نصب/مونتاژ
نصب/مونتاژ باید توسط فردی حرفه ای که مجاز به انجام این کار است، و همچنین با توجه کامل به مقررات مربوطه انجام شود.

Ersatzteilliste
Spare parts list

Liste des pièces de rechange
Lista parti di ricambio

Onderdelenlijst
Lista de repuestos

- 4x  80x30x2
- 4x  80x34x2
- 8 — 2x  90x43x2
- 2x  100x48x2
- 6x  110x55x2

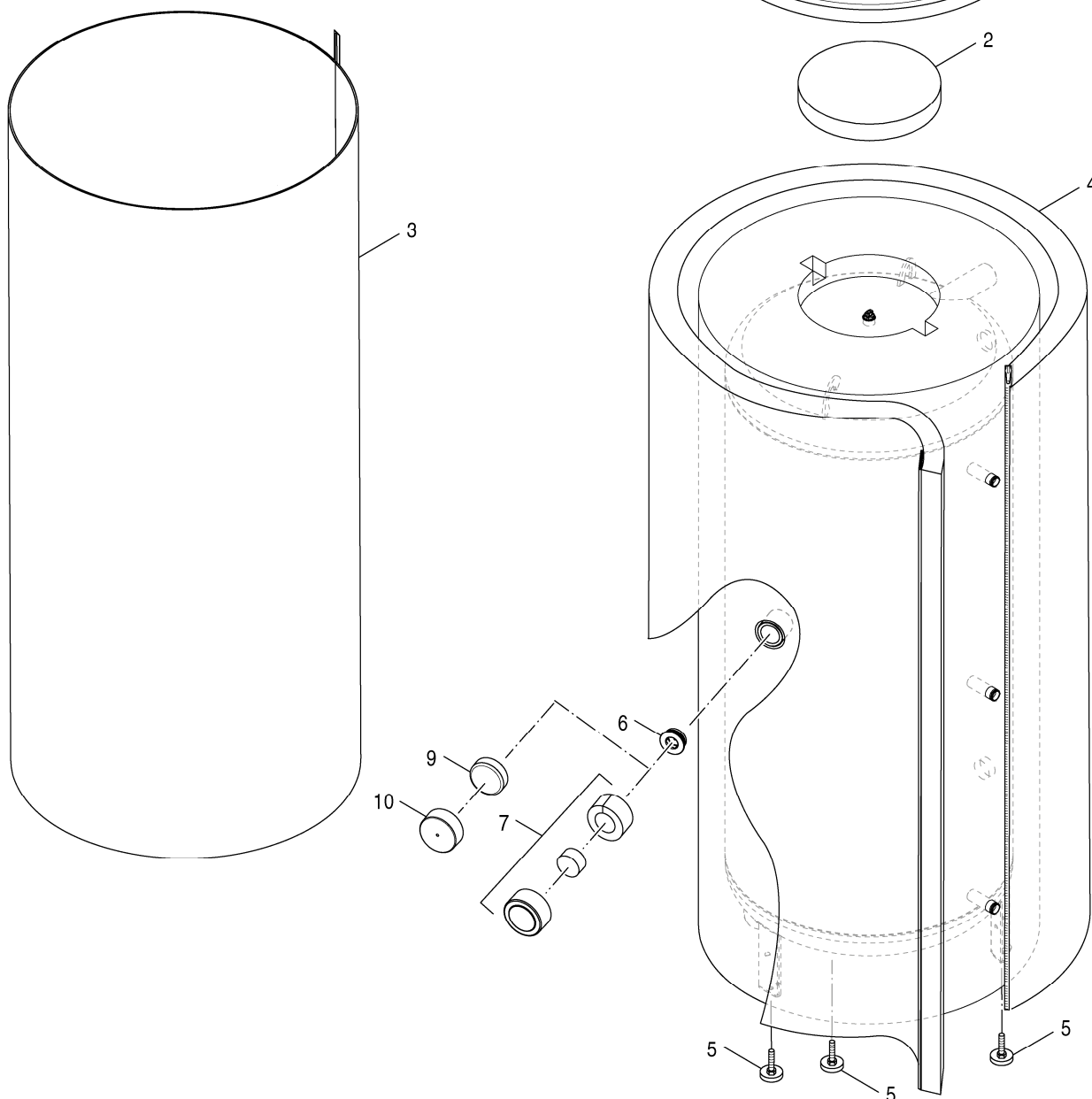

8738893758.aa.RO









1
Pufferspeicher B 500-6 ER
Buffer cylinder B 500-6 ER
Ballon tampon B 500-6 ER
Accumulatore puffer B 500-6 ER
Bufferboiler B 500-6 ER
Acumulador auxiliar B 500-6 ER

B 500 ER - B 1300-6 ER

Ersatzteilliste
Spare parts list

Liste des pièces de rechange
Lista parti di ricambio

Onderdelenlijst
Lista de repuestos

- | | | | | | |
|----|---|----------|----|---|------------|
| 4x |  | 80x30x2 | 6x |  | D90x38x20 |
| 4x |  | 80x34x2 | 5x |  | D90x25x20 |
| 2x |  | 90x43x2 | 12 |  | D140x58x20 |
| 2x |  | 100x48x2 | | | |
| 6x |  | 110x55x2 | | | |

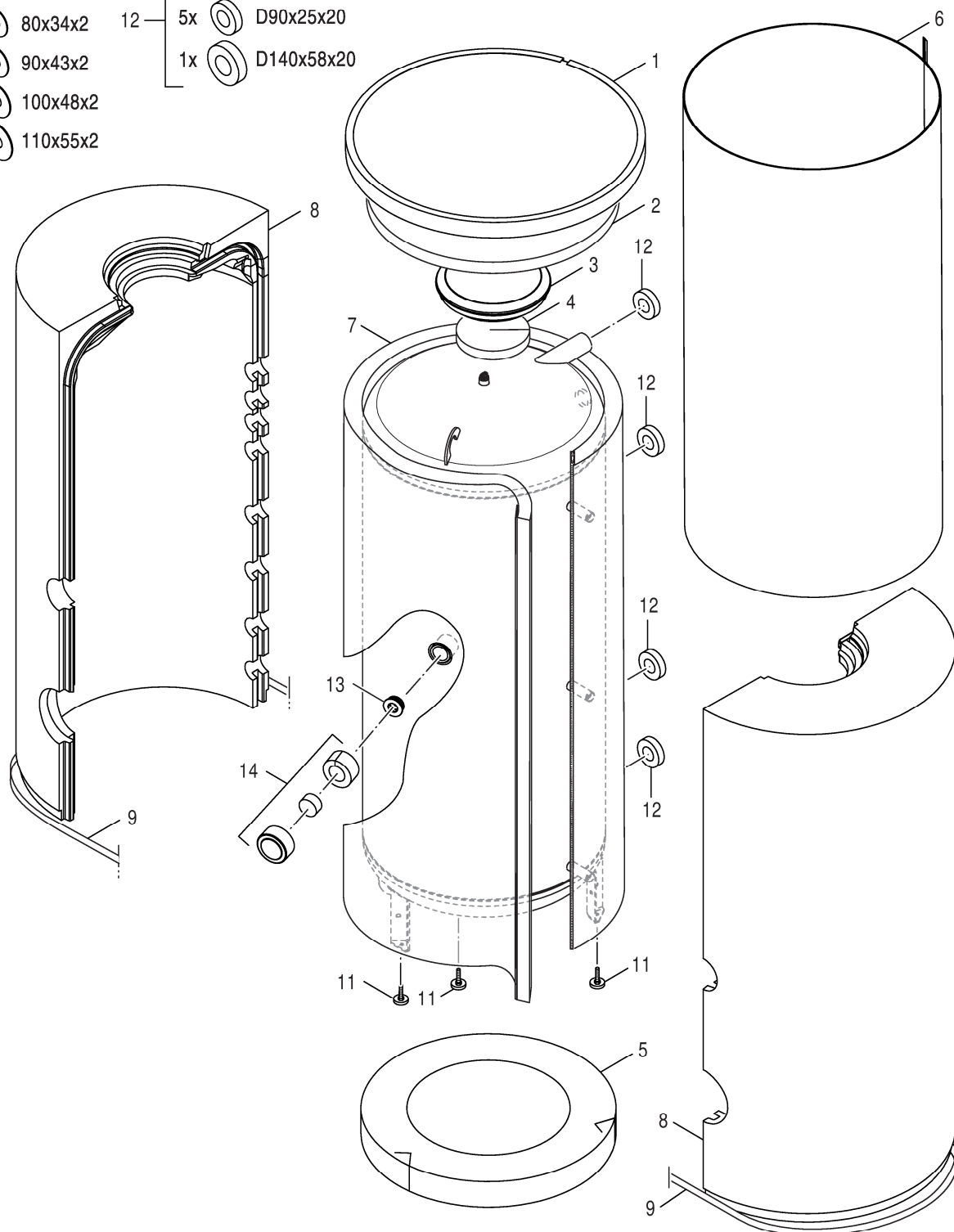

8738893759.aa.RO

- 2
- Pufferspeicher B 750-6 ER - 1300-6 ER
 - Buffer cylinder B 750-6 ER - 1300-6 ER
 - Ballon tampon B 750-6 ER - 1300-6 ER
 - Accumulatore puffer B 750-6 ER-1300-6 ER
 - Bufferboiler B 750-6 ER - 1300-6 ER
 - Acumulador auxiliar B 750-6 ER-1300-6ER

B 500 ER - B 1300-6 ER

Übersetzungsliste List of translations		Liste des traductions Traduzione delle descrizioni		Vertalinglijst Lista de traducciones	
Pos	Description	Denomination	Descrizione	Benaming	Descripción
1	Element of construction	Groupe de construction	Gruppo di costruzione	Montagegroep	Grupo de construcción
1	Cover Outer Case D850 Black	Couvercle Couvercle D850 noir	Copertura Coperchio D850 nero	Afdekking Deksel D850 zwart	Recubrimiento Tapa D850 negro
1	Cover Outer Case D850 white	Couvercle Couvercle D850 blanc	Copertura Coperchio D850 bianco	Afdekking Deksel D850 wit	Recubrimiento Tapa D850 blanc
1	Cover Outer Case D783 white	Couvercle Couvercle D783 blanc	Copertura Coperchio D783 bianco	Afdekking Deksel D783 wit	Recubrimiento Tapa D783 blanc
2	Seal Foam Rose D320x0x50	Mousse molle Rozet D320x0x50	Schiuma morbida Rosone D320x0x50	Zachtschuim Rozet D320x0x50	Espuma suave Rosetón D320x0x50
3	Cover Jacket P500 white packed	Habillage film P500 blanc	Pellicola di rivestimento P500 bianco	Foliemantel P500 wit	Plástico de protección P500 blanc
4	Insulation Jacket P500.6-40 S packed	Isolation P500.6-40 S	Coibentazione P500.6-40 S	Isolatie P500.6-40 S	Aislamiento P500.6-40 S
4	Insulation Jacket P500.6-40 W packed	Isolation P500.6-40 blanc	Coibentazione P500.6-40 bianco	Isolatie P500.6-40 wit	Aislamiento P500.6-40 blanc
5	Foot Set Tank 500-1000L 3 pc	Pieds tampon 500-1000L - 3pc	Piedini regolabili bollitori - 3 pezzi	Stelvoeten	Pies ajustable
6	Plug G 1 1/2" with PTFE-Ring PB2 SP	Bouchon G1 1/2" PB2	Tappo G 1 1/2" con anello di PTFE PB2	Pluggen G 1 1/2" met PTFE-ring PB2	Tapón G 1 1/2" con anillo de PTFE PB2
7	Cover E-sleeve white packed	Couvercle manchon chauffé électrique blanc	Copertura Riscaldamento manicotto bianco	Afdekking Elektrisch verwarming mouw wit	Recubrimiento blanc
7	Cover E-sleeve Black packed	Couvercle manchon chauffé électrique - noir	Copertura Riscaldamento manicotto - nero	Afdekking Elektrisch verwarm. mouw zwart	Recubrimiento - negro
8	Set rosettes self-adhesive S packed	Set rosettes auto-adhésif S	Set rosette autoadesive S	Set rozetten zelfklevende S	Set Rosetas autoadhesiva S
9	Cover muffle EPP	Couvercle EPP	Copertura tetto EPP	Afdekkap EPP	Recubrimiento EPP
10	Cover Immersion Heater Socket - white	Couvercle manchon chauffé électrique blanc	Copertura Riscaldamento manicotto bianco	Afdekking Elektrisch verwarming mouw wit	Recubrimiento blanc
	Thermometer 30 - 80 degree C	Thermometre 30-80#c pour LT	Termometro 30-80 gradi C	Thermometer TBS L/LT horizontaal	Termómetro analógico horizontal
	Bezel Set E-heater	Set de rosettes élément chauffant électri	Rosette per resistenze elettriche	Set rozetten elektr. verwarmingselement	Conjunto de 2 rosetas pretas
	Tool Circle Cutter D125mm packed	Outil coupe circulaire D125mm	Taglierina circolare utensile D125mm	Gereedschap cirkel cutting D125mm	Herramienta de corte circular D125mm
	Digital thermometer with capillary 3 DTA	Thermom#tre numérique DTA	SONDA BOLLITORE DIGITALE DTA	THERMOMETER DIGITAAL P500/750/100-120S	Termometro Digital SU750
	Trademark Bosch	Marquage Bosch	Logo Bosch	LOGO BOSCH ZELFKLEVEND	Marca Bosch
	Case Thermometer 3T packed	Thermom#tre boîtier 3T	Termometro Involucro 3T	Thermometer behuizing 3T	Termómetro carcasa 3T
	Case Thermometer 1T packed	Thermom#tre boîtier 1T	Termometro Involucro 1T	Thermometer behuizing 1T	Termómetro carcasa 1T
2	Element of construction	Groupe de construction	Gruppo di costruzione	Montagegroep	Grupo de construcción
1	Cover Top 960 white packed	Couvercle Couvercle 960 blanc	Copertura Coperchio 960 bianco	Afdekking Deksel 960 wit	Recubrimiento Tapa 960 blanc
1	Cover Top D950x50 white packed	Couvercle Couvercle D950x50 blanc	Copertura Coperchio D950x50 bianco	Afdekking Deksel D950x50 wit	Recubrimiento Tapa D950x50 blanc
1	Cover Top D1060x50 white packed	Couvercle Couvercle D1060x50 blanc	Copertura Coperchio D1060x50 bianco	Afdekking Deksel D1060x50 wit	Recubrimiento Tapa D1060x50 blanc
2	Insulation 750/1000-80V top	Isolation 750/1000-80V Couvercle	Coibentazione 750/1000-80V Coperchio	Isolatie 750/1000-80V Deksel	Aislamiento 750/1000-80V Tapa
3	Plug EPS upper section D370	Bouchon EPS partie supérieure D370	Tappo EPS Parte superiore D370	Stop EPS bovendeel D370	Tapon EPS parte superior D370
4	Seal Foam Rose 280x0x50 packed	Mousse molle Rozet 280x0x50	Schiuma morbida Rosone 280x0x50	Zachtschuim Rozet 280x0x50	Espuma suave Rosetón 280x0x50
5	Insulation bottom D790x80V	Isolation bas D790x80V	Coibentazione sotto D790x80V	Isolatie onder D790x80V	Aislamiento debajo D790x80V
5	Insulation Bottom 820x100 packed	Isolation bas 820x100	Coibentazione sotto 820x100	Isolatie onder 820x100	Aislamiento debajo 820x100
5	Insulation Bottom 930x100 packed	Isolation bas 930x100	Coibentazione sotto 930x100	Isolatie onder 930x100	Aislamiento debajo 930x100
6	Cover Jacket P1300 white packed	Habillage film P1300 blanc	Pellicola di rivestimento P1300 bianco	Foliemantel P1300 wit	Plástico de protección P1300 blanc
6	Cover Jacket P750 white packed	Habillage film P750 blanc	Pellicola di rivestimento P750 bianco	Foliemantel P750 wit	Plástico de protección P750 blanc
6	Cover Jacket P1000 white packed	Habillage film P1000 blanc	Pellicola di rivestimento P1000 bianco	Foliemantel P1000 wit	Plástico de protección P1000 blanc
7	Insulation Buffer 1000.5V E Bo/Ju packed	Isolation Buffer 1000.5V E Bo/Ju	Isolamento Buffer 1000.5V E Bo/Ju	Isolatie Buffer 1000.5V E Bo/Ju	Aislamiento Buffer 1000.5V E Bo/Ju
7	Insulation Buffer 750.5V E Bo/Ju packed	Isolation Buffer 750.5V E Bo/Ju	Isolamento Buffer 750.5V E Bo/Ju	Isolatie Buffer 750.5V E Bo/Ju	Aislamiento Buffer 750.5V E Bo/Ju
8	Insulation Tank P750-C Packed	Isolation ballon P750-C	Coibentazione accumulatore P750-C	Isolatie boiler P750-C	Aislamiento acumulador P750-C
8	Insulation Tank P1000-C Packed	Isolation ballon P1000-C	Coibentazione accumulatore P1000-C	Isolatie boiler P1000-C	Aislamiento acumulador P1000-C
8	Insulation Tank P1300-C Packed	Isolation ballon P1300-C	Coibentazione accumulatore P1300-C	Isolatie boiler P1300-C	Aislamiento acumulador P1300-C
9	Case Fixing packed	Sangle	Nastro tensore	Spanband	Cintas de sujeción
11	Foot Set Tank 500-1000L 3 pc	Pieds tampon 500-1000L - 3pc	Piedini regolabili bollitori - 3 pezzi	Stelvoeten	Pies ajustable
12	Seal Foam Rose P	Set Mousse molle Rozet P	Set Schiuma morbida Rosone P	Set Zachtschuim Rozet P	Set Espuma suave Rosetón P
13	Plug G 1 1/2" with PTFE-Ring PB2 SP	Bouchon G1 1/2" PB2	Tappo G 1 1/2" con anello di PTFE PB2	Pluggen G 1 1/2" met PTFE-ring PB2	Tapón G 1 1/2" con anillo de PTFE PB2
14	Cover E-sleeve white packed	Couvercle manchon chauffé électrique blanc	Copertura Riscaldamento manicotto bianco	Afdekking Elektrisch verwarming mouw wit	Recubrimiento blanc
15	Set rosettes self-adhesive S packed	Set rosettes auto-adhésif S	Set rosette autoadesive S	Set rozetten zelfklevende S	Set Rosetas autoadhesiva S
	Thermometer 30 - 80 degree C	Thermometre 30-80#c pour LT	Termometro 30-80 gradi C	Thermometer TBS L/LT horizontaal	Termómetro analógico horizontal
	Bezel Set E-heater	Set de rosettes élément chauffant électri	Rosette per resistenze elettriche	Set rozetten elektr. verwarmingselement	Conjunto de 2 rosetas pretas
	Cover Socket EPP packed	Couvercle Boîtier EPP	Copertura Boccola EPP	Afdekking Huls EPP	Recubrimiento Manguito EPP
	Digital thermometer with capillary 3 DTA	Thermom#tre numérique DTA	SONDA BOLLITORE DIGITALE DTA	THERMOMETER DIGITAAL P500/750/100-120S	Termometro Digital SU750
	Trademark Bosch	Marquage Bosch	Logo Bosch	LOGO BOSCH ZELFKLEVEND	Marca Bosch
	Case Thermometer 3T packed	Thermom#tre boîtier 3T	Termometro Involucro 3T	Thermometer behuizing 3T	Termómetro carcasa 3T
	Case Thermometer 1T packed	Thermom#tre boîtier 1T	Termometro Involucro 1T	Thermometer behuizing 1T	Termómetro carcasa 1T

Gerätetypen Types of appliances		Types de chaudières Tipo apparecchi		Toesteltypen Tipos de aplicaciones	
Gerät Appliance Chaudière Apparecchio Toestel Aparato	Bestell-Nr. Ordering no. Numéro de commande N° d'ordine Bestellnummer Número el ordenar	Land Country Pays Paese Land Paese	S-Nr. S-Nr. S-Nr. S-Nr. S-Nr.	Bemerkungen Remarks Remarques Osservazioni Opmerkingen Observaciones	
B 500-6 ER 1 B	7 735 501 568	Belgien, Deutschland			
B 750-6 ER C	7 735 501 071	Belgien, Deutschland			
B 1000-6 ER C	7 735 501 075	Belgien, Deutschland			
B 1300-6 ER C	7 735 501 077	Belgien, Deutschland			
B 500-6 ER B	7 735 501 067	Deutschland			
B 500-6 ER B	8 735 100 467	Deutschland, Dänemark			
B 500-6 ER C	7 735 501 065	Deutschland, Ukraine			
Puffer B 750-6 ER E	8 735 100 469	Dänemark, Ukraine			
Puffer B 1000-6 ER E	8 735 100 471	Dänemark, Ukraine			
B 750-6 ER E	7 735 501 069	Ukraine			
B 1000-6 ER E	7 735 501 073	Ukraine			



BOSCH

Bosch Thermotechnik GmbH
Junkersstr. 20-24
D-73249 Wernau / Germany