

WAGO I/O System 750/753

16-channel digital output; 24 VDC; 0.5 A; high-side switching

750-1504



© 2026 WAGO GmbH & Co. KG
All rights reserved.

WAGO GmbH & Co. KG

Hansastraße 27
D - 32423 Minden

Phone: +49 571/887 – 0
E-Mail: ✉ info@wago.com
Internet: 🌐 www.wago.com

Technical Support

Phone: +49 571/887 – 44555
E-Mail: ✉ support@wago.com
Internet: 🌐 www.wago.com/support

Every conceivable measure has been taken to ensure the accuracy and completeness of this documentation. However, as errors can never be fully excluded, we always appreciate any information or suggestions for improving the documentation.

E-Mail: ✉ documentation@wago.com

We wish to point out that the software and hardware terms as well as the trademarks of companies used and/or mentioned in the present documentation are generally protected by trademark or patent.

WAGO is a registered trademark of WAGO Verwaltungsgesellschaft mbH.

Table of Contents

1 Provisions	4
1.1 Scope of Applicability	4
2 Overview	5
3 Properties	6
3.1 View.....	6
3.2 Indicators.....	7
3.3 Wiring Interface.....	8
3.4 Power Jumper Contacts.....	9
3.5 Circuit Diagram.....	10
4 Functions	11
4.1 Signal Processing.....	11
4.2 Process Image	11
5 Planning	12
5.1 Compatibility.....	12
5.2 Requirements for Wiring and Accessories	12
5.3 Connection Example	12
5.4 Use in Safety Applications.....	13
5.4.1 Connection to Safety Switching Devices or F I/O Modules	14
5.4.2 Connection Examples for Use in Safety Applications.....	15
6 Appendix	16
6.1 Technical Data, Approvals, Guidelines and Standards.....	16
6.1.1 Data sheet 750-1504.....	17

1 Provisions

1.1 Scope of Applicability

This document applies to the following product:

🔗 **750-1504** (16DO 24V DC 0.5A) 16-channel digital output; 24 VDC; 0.5 A; high-side switching.

From hardware version	05
From firmware version	--
Product detail page	🔗 www.wago.com/750-1504

Note

Note applicable documents!

The complete operating instructions for the product consists of several, applicable documents. The product must only be installed and operated in accordance with the complete operating instructions. Knowledge of all applicable documents is required for proper use. You can find all documents and information on the product detail page.

Applicable document

📄 System Manual I/O System 750/753

- Provisions
- Safety
- Planning
- Transport and Storage
- Assembly and Disassembly
- Conductor Termination
- Decommissioning

2 Overview

The I/O module transmits binary control signals to connected actuators (e.g., magnetic valves, contactors, transmitters, relays or other electrical loads).

The I/O module is suitable for interference-free use in safety circuits.

The I/O module has 16 output channels, allowing direct connection of single-wire actuators.

The I/O module's outputs provide high-side switching. If the signal status of an output channel is "high," the 24 V potential for the field power supply is switched to the corresponding output connection.

For each channel, a green status LED indicates the signal status.

The field level and the system level are electrically isolated from one another.

The I/O module can be operated on all head stations of the WAGO I/O System 750/753.

3 Properties

3.1 View

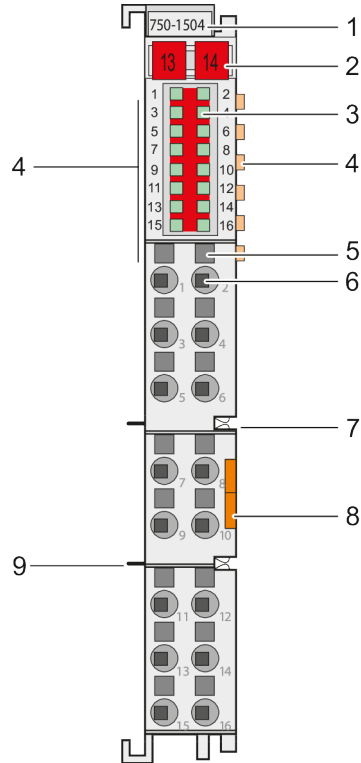

Figure 1: View

1	Item number	☞ Scope of Applicability [> 4]
2	Slot for Mini-WSB (optional)	☐ System Manual I/O System 750/753
3	Status LEDs	☞ Indicators [> 7]
4	Data contacts	☐ System Manual I/O System 750/753
5	Access to open the associated Push-in CAGE CLAMP® connection	☐ System Manual I/O System 750/753
6	CAGE CLAMP® connection	☞ Wiring Interface [> 8] and ☐ System Manual I/O System 750/753
7	Power jumper contacts (spring)	☞ Power Jumper Contacts [> 9] and ☐ System Manual I/O System 750/753
8	Release tab	☐ System Manual I/O System 750/753
9	Power jumper contacts (blade)	☞ Power Jumper Contacts [> 9] and ☐ System Manual I/O System 750/753

3.2 Indicators

For each channel, a green status LED indicates the signal status.

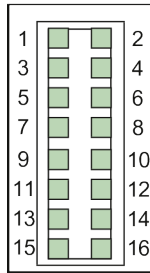

Figure 2: Indicators

Channel	Designation	LED	State	Function
1	DO 1 status	1	Off	DO 1 output: signal voltage (0)
			Green	DO 1 output: signal voltage (1)
2	DO 2 status	2	Off	DO 2 output: signal voltage (0)
			Green	DO 2 output: signal voltage (1)
3	DO 3 status	3	Off	DO 3 output: signal voltage (0)
			Green	DO 3 output: signal voltage (1)
4	DO 4 status	4	Off	DO 4 output: signal voltage (0)
			Green	DO 4 output: signal voltage (1)
5	DO 5 status	5	Off	DO 5 output: signal voltage (0)
			Green	DO 5 output: signal voltage (1)
6	DO 6 status	6	Off	DO 6 output: signal voltage (0)
			Green	DO 6 output: signal voltage (1)
7	DO 7 status	7	Off	DO 7 output: signal voltage (0)
			Green	DO 7 output: signal voltage (1)
8	DO 8 status	8	Off	DO 8 output: signal voltage (0)
			Green	DO 8 output: signal voltage (1)
9	DO 9 status	9	Off	DO 9 output: signal voltage (0)
			Green	DO 9 output: signal voltage (1)
10	DO 10 status	10	Off	DO 10 output: signal voltage (0)
			Green	DO 10 output: signal voltage (1)
11	DO 11 status	11	Off	DO 11 output: signal voltage (0)
			Green	DO 11 output: signal voltage (1)
12	DO 12 status	12	Off	DO 12 output: signal voltage (0)
			Green	DO 12 output: signal voltage (1)
13	DO 13 status	13	Off	DO 13 output: signal voltage (0)
			Green	DO 13 output: signal voltage (1)
14	DO 14 status	14	Off	DO 14 output: signal voltage (0)
			Green	DO 14 output: signal voltage (1)
15	DO 15 status	15	Off	DO 15 output: signal voltage (0)
			Green	DO 15 output: signal voltage (1)
16	DO 16 status	16	Off	DO 16 output: signal voltage (0)
			Green	DO 16 output: signal voltage (1)

3.3 Wiring Interface

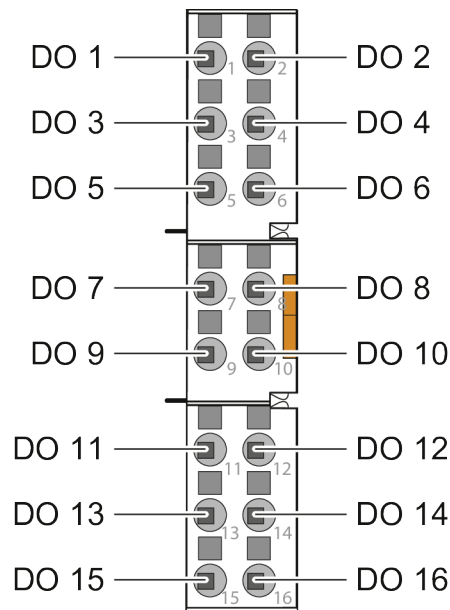

Figure 3: Push-in CAGE CLAMP® Connections

Channel	Designation	Connection	Function
1	DO 1	1	Output DO 1: signal voltage
2	DO 2	2	Output DO 2: signal voltage
3	DO 3	3	Output DO 3: signal voltage
4	DO 4	4	Output DO 4: signal voltage
5	DO 5	5	Output DO 5: signal voltage
6	DO 6	6	Output DO 6: signal voltage
7	DO 7	7	Output DO 7: signal voltage
8	DO 8	8	Output DO 8: signal voltage
9	DO 9	9	Output DO 9: signal voltage
10	DO 10	10	Output DO 10: signal voltage
11	DO 11	11	Output DO 11: signal voltage
12	DO 12	12	Output DO 12: signal voltage
13	DO 13	13	Output DO 13: signal voltage
14	DO 14	14	Output DO 14: signal voltage
15	DO 15	15	Output DO 15: signal voltage
16	DO 16	16	Output DO 16: signal voltage

3.4 Power Jumper Contacts

The potential for the field supply is fed in via the blade contacts and passed on via the spring contacts.

For additional information on the Power Jumper Contacts, please see [System Manual I/O System 750/753](#).

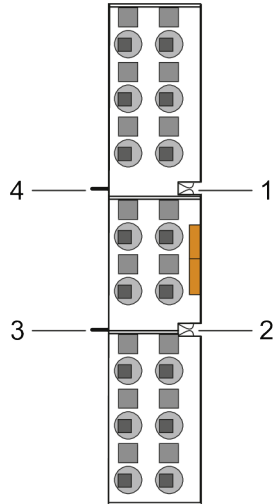

Figure 4: Power Jumper Contacts

No.	Type
1	Groove with spring contact
2	
3	Blade contact
4	

Arrangement in the Bus Node

For mechanical arrangement of the I/O module, the previous component must have at least 2 open grooves for accommodating the blade contacts.

For electrical compatibility requirements see Section [Circuit Diagram \[p. 10\]](#).

3.5 Circuit Diagram

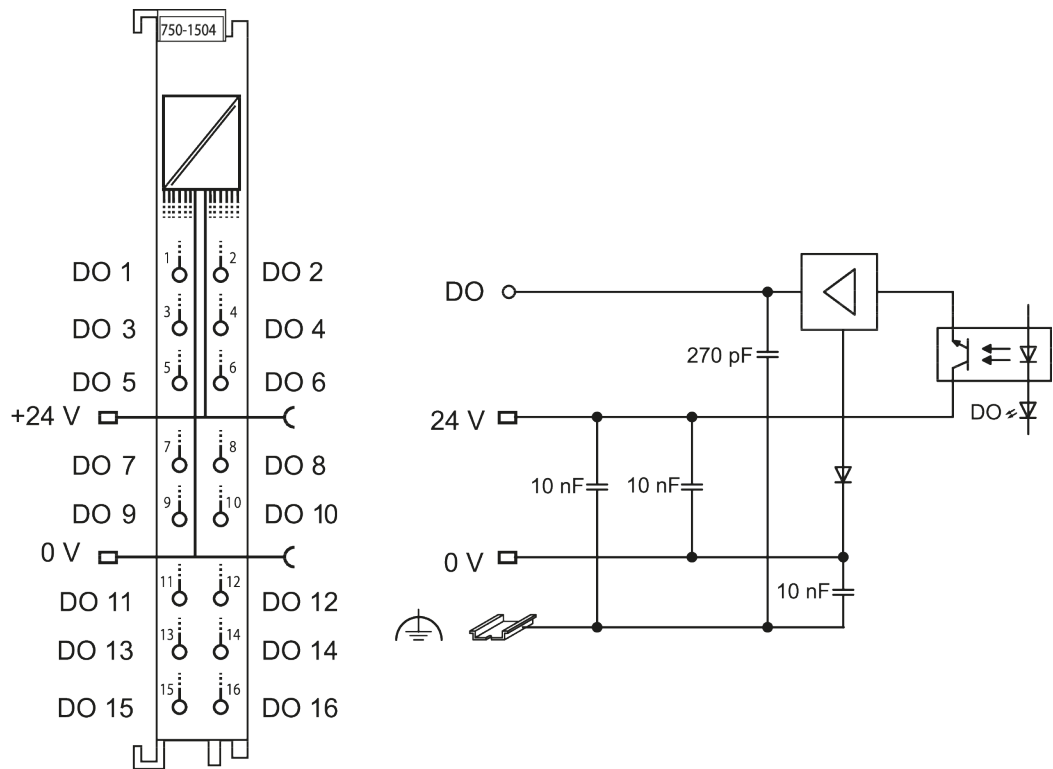

Figure 5: Circuit Diagram

For information on the system power supply, please see [System Manual I/O System 750/753](#).

4 Functions

4.1 Signal Processing

The I/O module's outputs provide high-side switching. If the signal status of an output channel is "high," the 24 V potential for the field power supply is switched to the corresponding output connection.

4.2 Process Image

Table 1: Output bits 0 .. 7

Bit 7	Bit 6	Bit 5	Bit 4	Bit 3	Bit 2	Bit 1	Bit 0
DO 8	DO 7	DO 6	DO 5	DO 4	DO 3	DO 2	DO 1
DO 1		DO 1 signal state – digital output channel 1					
DO 2		DO 2 signal state – digital output channel 2					
DO 3		DO 3 signal state – digital output channel 3					
DO 4		DO 4 signal state – digital output channel 4					
DO 5		DO 5 signal state – digital output channel 5					
DO 6		DO 6 signal state – digital output channel 6					
DO 7		DO 7 signal state – digital output channel 7					
DO 8		DO 8 signal state – digital output channel 8					

Table 2: Output bits 8 .. 16

Bit 7	Bit 6	Bit 5	Bit 4	Bit 3	Bit 2	Bit 1	Bit 0
DO 16	DO 15	DO 14	DO 13	DO 12	DO 11	DO 10	DO 9
DO 9		DO 9 signal state – digital output channel 9					
DO 10		DO 10 signal state – digital output channel 10					
DO 11		DO 11 signal state – digital output channel 11					
DO 12		DO 12 signal state – digital output channel 12					
DO 13		DO 13 signal state – digital output channel 13					
DO 14		DO 14 signal state – digital output channel 14					
DO 15		DO 15 signal state – digital output channel 15					
DO 16		DO 16 signal state – digital output channel 16					

5 Planning

This section provides helpful information for planning the use of the product in a node.

5.1 Compatibility

The I/O module can be operated on all head stations of the WAGO I/O System 750/753.

5.2 Requirements for Wiring and Accessories

To protect the I/O module against overload, use a supply module with a fuse (e.g., Item No.: [750-601](#) or [750-610](#)).

If applicable, use appropriate potential multiplication modules (e.g., item no. [750-1605](#), [750-1606](#) or [750-1607](#)) for the power supply to the actuators.

Use a suitable protective circuit to limit the induction voltage, such a recovery diode, parallel to the load. Inductive voltage limitation prevents damage to the I/O module's electronics when inductive loads are switched off.

An operating tool with a 2.5 mm blade (e.g., Item No.: [210-719](#)) is required for opening the Push-in CAGE CLAMP® connections.

5.3 Connection Example

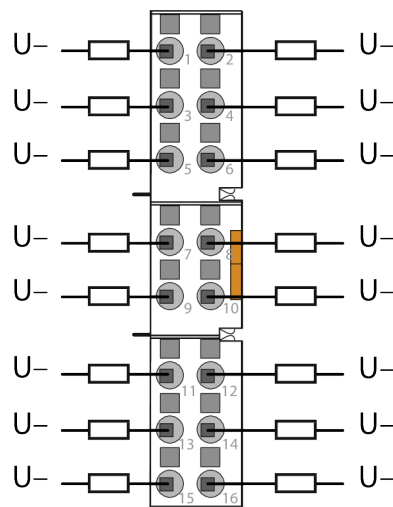

Figure 6: Example

5.4 Use in Safety Applications

The I/O module is suitable for interference-free use in safety circuits.

If the field-side supply is shut down via a safety switching device, the safety function of the I/O module is not active. If the interference-free I/O module is used correctly in a safety-related application, this does not affect either the SIL (or the Performance Level and category) achieved by the circuit. Note the following information.

- **Only operate with functional extra-low voltage**
When using interference-free I/O modules, only use SELV/PELV-capable power supplies for the 24 VDC power supply.
- **Observe maximum voltage**
Even in the event of failure, only a maximum voltage of U_{max} must be allowed to act on the interference-free I/O module; otherwise irreparable damage to the I/O module could occur. Use a power supply with active voltage limitation (overvoltage protection) or an alternate component. For the interference-free I/O module, the field supply voltage is:
 $U_{max} < 32 \text{ V}$
- **Ensure protection type IP54**
Protection type IP54 is mandatory. Therefore, integration and operation of the interference-free I/O module is only allowed in switch boxes or control cabinets with protection type IP54 or higher.
- **Protect the outputs against feedback**
The 24 V power supply must never be applied to the output of an interference-free I/O module. The system would not detect such a wiring error.
- **Avoid reverse power supply of the I/O module**
A group of interference-free I/O modules must only be powered by a safety switching device. It is absolutely essential to avoid reverse power supply.
- **Prevent short circuits between outputs**
It is absolutely essential to prevent short circuits between the outputs of different interference-free I/O modules. The system would not detect such short circuits.

According to EN ISO 13849-2, the following measures are required for an "external voltage" fault exclusion:

- Use of cables routed separately and
- Protection from external damage (e.g., with cable duct).

5.4.1 Connection to Safety Switching Devices or F I/O Modules

When the interference-free I/O module is used in safety-related applications, the I/O modules belonging to a safety switching device must be combined to form a potential group. The power supply of the potential group must only be provided via the following supply/filter modules:

Table 3: Supply/Filter Modules for Setting up a Potential Group

Supply module	Item no.: 750-601
	Item no.: 750-602
Filter module	Item no.: 750-626

Either a supply module or a distance module without power jumper contacts (item no.: [750-616](#)) must be connected at the end of the potential group.

Safety switching device /
F I/O module

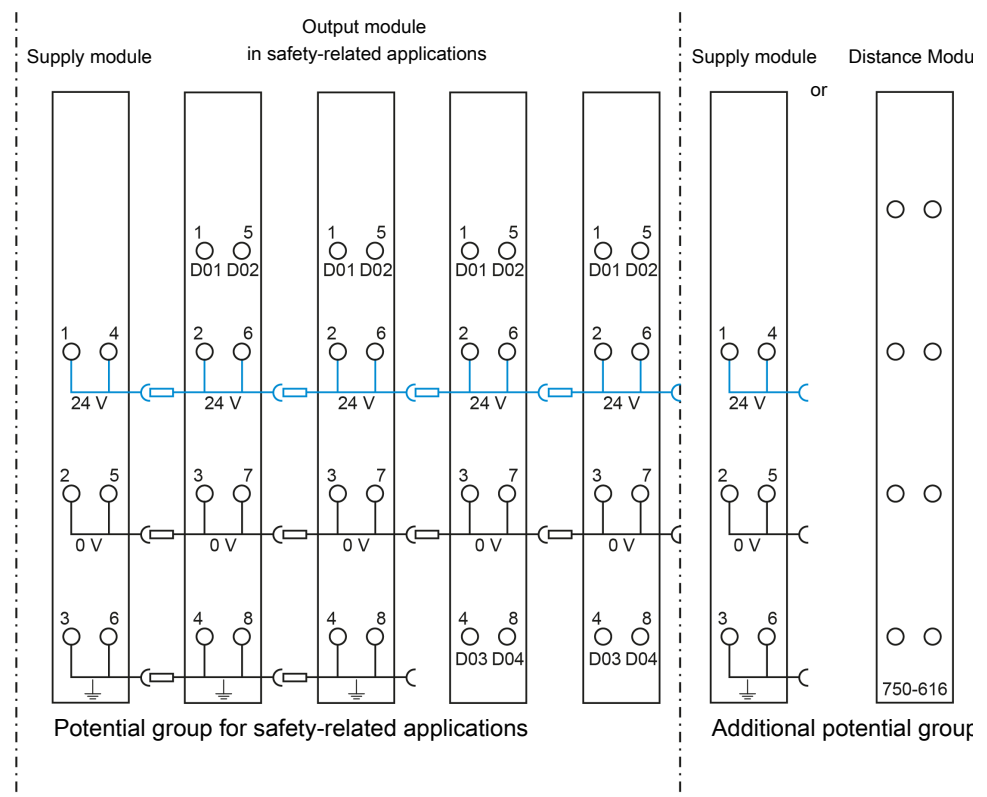

Figure 7: Setting Up a Potential Group (Example)

5.4.2 Connection Examples for Use in Safety Applications

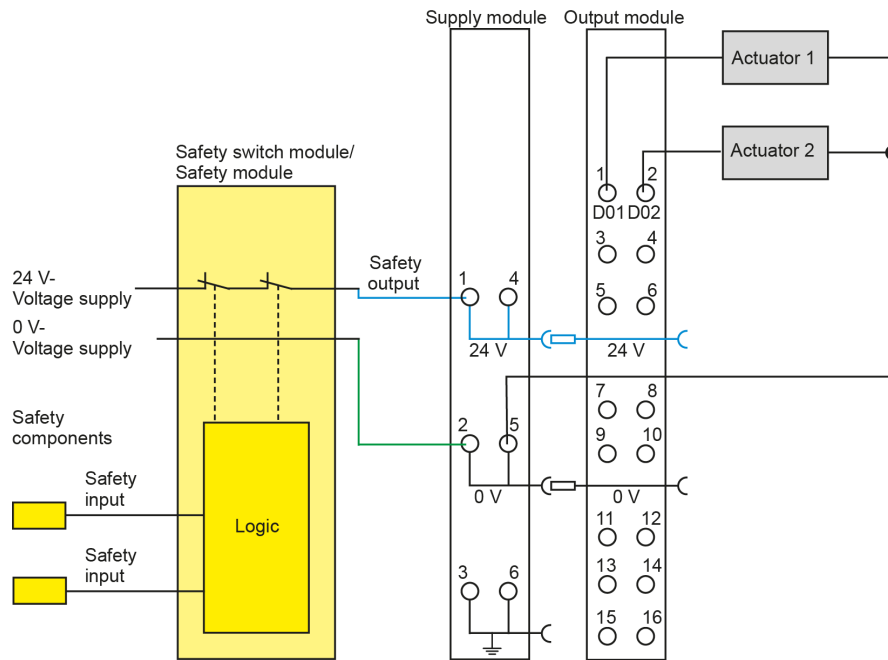

Figure 8: Two-Channel, **Single-Pole** Power Supply Shutdown

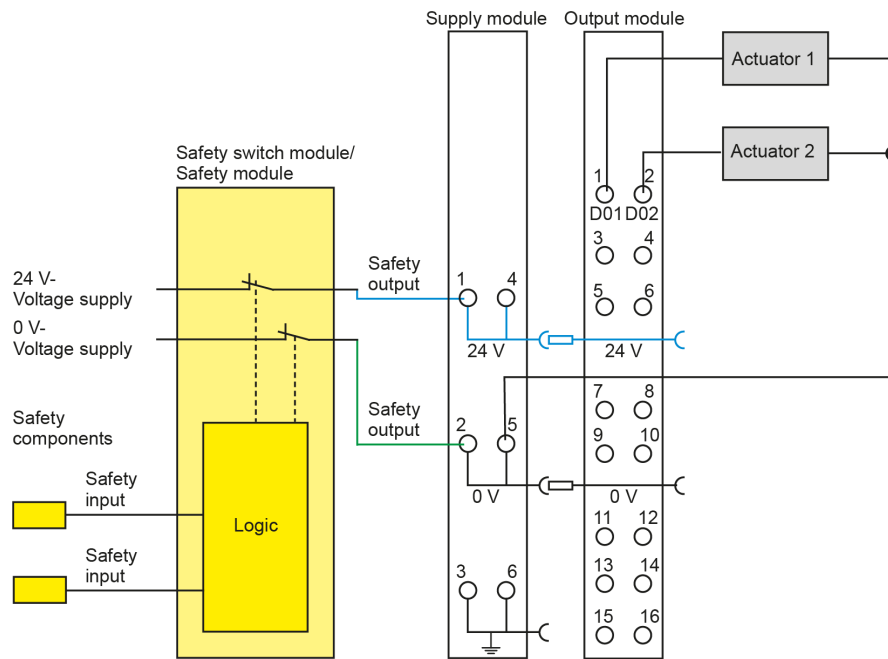

Figure 9: Two-Channel, **Two-Pole** Power Supply Shutdown

6 Appendix

6.1 Technical Data, Approvals, Guidelines and Standards

Note

Subject to changes!

Please also observe the further product documentation! You can generate the current datasheet at any time at: www.wago.com /<item number>.

See also

-  Data sheet 750-1504 [► 17]



Technical data

Number of digital outputs	16
Total number of channels (module)	16
Signal type	Digital
Signal type (voltage)	24 VDC
Actuator connection	16 x (1-wire)
Output characteristic	high-side switching
Output current per channel	0.5 A
Output current	short-circuit-protected
Load type	Resistive, inductive, lamp load
Switching frequency (max.)	1 kHz
Output data width (internal) max.	16 bits
Supply voltage (system)	5 VDC; via data contacts
Current consumption (5 V system supply)	40 mA
Supply voltage (field)	24 VDC (-25 ... +30 %); via power jumper contacts (power supply via blade contact; transmission (field side supply voltage only) via spring contact)
Current consumption, field supply (module with no external load)	29 mA
Isolation	500 V system/field
Indicators	LED (1-16) green: Status DO 1 ... DO 16
Number of incoming power jumper contacts	2
Number of outgoing power jumper contacts	2
Current carrying capacity (power jumper contacts)	10 A

Connection Data

Connection technology: I/O	16 x Push-in CAGE CLAMP® (outputs)
Connectable conductor materials	Copper
Connection type	Output
Solid conductor	0.08 ... 1.5 mm ² / 28 ... 16 AWG
Fine-stranded conductor	0.25 ... 1.5 mm ² / 22 ... 16 AWG
Strip length	8 ... 9 mm / 0.31 ... 0.35 inches

Physical data

Width	12 mm / 0.472 inches
Height	100 mm / 3.937 inches
Depth	69 mm / 2.717 inches
Depth from upper-edge of DIN-rail	61.8 mm / 2.433 inches

Mechanical data

Mounting type	DIN-35 rail
Pluggable connector	fixed

Material data

Color	light gray
Housing material	Polycarbonate; polyamide 6.6
Fire load	0.844 MJ
Weight	49.9 g
Conformity marking	CE

Environmental requirements

Ambient temperature (operation)	0 ... +55 °C
Ambient temperature (storage)	-40 ... +85 °C
Protection type	IP20
Pollution degree	2 per IEC 61131-2
Operating altitude	0 ... 2000 m / 0 ... 6562 ft
Mounting position	Horizontal left, horizontal right, horizontal top, horizontal bottom, vertical top and vertical bottom
Relative humidity (without condensation)	95 %
Vibration resistance	4g per IEC 60068-2-6
Shock resistance	15g per IEC 60068-2-27
EMC immunity to interference	per EN 61000-6-2, marine applications
EMC emission of interference	per EN 61000-6-3, marine applications
Exposure to pollutants	per IEC 60068-2-42 and IEC 60068-2-43
Permissible H ₂ S contaminant concentration at a relative humidity 75 %	10 ppm
Permissible SO ₂ contaminant concentration at a relative humidity 75 %	25 ppm

Product Classification

UNSPSC	32151705
eCl@ss 10.0	27-24-26-04
eCl@ss 9.0	27-24-26-04
ETIM 9.0	EC001599
ETIM 10.0	EC001599
ECCN	NO US CLASSIFICATION

Environmental Product Compliance

CAS-No.	1303-86-2 1317-36-8 7439-92-1 75980-60-8
REACH Candidate List Substance	Diboron trioxide Lead Lead monoxide Phosphine oxide, diphenyl(2,4,6-trimethylbenzoyl)-
RoHS Compliance Status	Compliant,With Exemption
RoHS Exemption	7(a) 7(c)-I
SCIP notification number (Austria)	b0f045e7-d178-4dff-b357-d4b87e122ddc
SCIP notification number (Belgium)	8fdf9103-120e-41da-962e-8a4778a35cb8
SCIP notification number (Bulgaria)	ccf699ac-4477-4350-b857-2039b462633f
SCIP notification number (Czech Republic)	4bff8e53-ecae-4fd6-b3a4-cdc43fd20f6c
SCIP notification number (Denmark)	3c965ddd-cfc2-420e-a09f-5a4d8781b588
SCIP notification number (Finland)	a21bd430-05dc-4484-9a0f-df5b014b19c7
SCIP notification number (France)	2cb79c20-e6f8-4390-bfa3-116908b95fbd
SCIP notification number (Germany)	4aa764fe-e251-4558-a80d-978e6aab38f6

Environmental Product Compliance

SCIP notification number (Hungary)	3f3aaf6d-4879-494c-a3d5-dcc0fceed75
SCIP notification number (Italy)	acf1ab18-af25-4b22-8f12-099a85a225ed
SCIP notification number (Netherlands)	d5ef9f95-5357-4bda-9d79-c6f6f8a5b219
SCIP notification number (Poland)	0a5ecd33-c7b9-47f4-b94d-70c567167514
SCIP notification number (Romania)	1cba2f0c-edbb-4944-b423-d60e0bc174c7
SCIP notification number (Sweden)	c0209038-643d-44c6-8b33-8c198fb02536

Approvals / Certificates

General approvals



Approval	Standard	Certificate Name
EAC GZO Almaty Standart	TP TC 020/2011	EAC CoC 03083
KC National Radio Research Agency	Article 58-2, Clause 3	MSIP-REM-W43-DOM750
UL Underwriters Laboratories Inc. (ORDINARY LOCATIONS)	UL 508	E175199

Declarations of conformity and manufacturer's declarations

Approval	Standard	Certificate Name
EU-Declaration of Conformity WAGO GmbH & Co. KG	-	-
UK-Declaration of Conformity WAGO GmbH & Co. KG	-	-

Approvals for marine applications



Approval	Standard	Certificate Name
ABS American Bureau of Shipping	-	22-2219060
BSH Bundesamt fuer Seeschifffahrt und Hydrographie	-	1104
BV Bureau Veritas S.A.	-	30389/C0 BV
DNV DNV GL SE	DNV-CG-0339, Aug. 2021	TAA0000194
KR Korean Register of Shipping	-	KR HMB05880-AC001
LR Lloyds Register EMEA	-	LR22180952TA
PRS Polski Rejestr Statków	-	TE/1101/880590/23
RINA RINA Germany GmbH	-	ELE343521XG001

Approvals for hazardous areas



Approval	Standard	Certificate Name
ATEX TUEV Nord Cert GmbH	EN 60079-0	TUEV14ATEX148929X (II 3 G Ex ec IIC T4 Gc)
CCCEX CQST/CNEX	CNCA-C23-01	2020312310000213 (Ex ec IIC T4 Gc)
IECEX TUEV Nord Cert GmbH	IEC 60079-0	IECEX TUN 14.0035 X (Ex ec IIC T4 Gc)
INMETRO TUV Rheinland do Brasil Ltda.	IEC 60079-0	TUV 12.1297 X
UKEX WAGO GmbH & Co. KG	EN 60079-0	UKCA_WA GO22UKEX003X_ec
UL Underwriters Laboratories Inc. (HAZARDOUS LOCATIONS)	UL 121201	E198726

Subject to changes. Please also observe the further product documentation!

Current addresses can be found at: www.wago.com

List of Tables

Table 1	Output bits 0 .. 7	11
Table 2	Output bits 8 .. 16.....	11
Table 3	Supply/Filter Modules for Setting up a Potential Group	14

List of Figures

Figure 1	View	6
Figure 2	Indicators	7
Figure 3	Push-in CAGE CLAMP® Connections	8
Figure 4	Power Jumper Contacts	9
Figure 5	Circuit Diagram	10
Figure 6	Example	12
Figure 7	Setting Up a Potential Group (Example).....	14
Figure 8	Two-Channel, Single-Pole Power Supply Shutdown.....	15
Figure 9	Two-Channel, Two-Pole Power Supply Shutdown	15

WAGO GmbH & Co. KG

Postfach 2880 · D - 32385 Minden
Hansastraße 27 · D - 32423 Minden

✉ info@wago.com
🌐 www.wago.com

Headquarters	+49 571/887 – 0
Sales	+49 (0) 571/887 – 44 222
Order Service	+49 (0) 571/887 – 44 333