

WAGO-I/O-SYSTEM 750

Manual



750-628

Coupler module for internal data bus extension

Version 1.2.0

© 2016 WAGO Kontakttechnik GmbH & Co. KG
All rights reserved.

WAGO Kontakttechnik GmbH & Co. KG

Hansastraße 27
D-32423 Minden

Phone: +49 (0) 571/8 87 – 0
Fax: +49 (0) 571/8 87 – 1 69

E-Mail: info@wago.com

Web: <http://www.wago.com>

Technical Support

Phone: +49 (0) 571/8 87 – 5 55
Fax: +49 (0) 571/8 87 – 85 55

E-Mail: support@wago.com

Every conceivable measure has been taken to ensure the accuracy and completeness of this documentation. However, as errors can never be fully excluded, we always appreciate any information or suggestions for improving the documentation.

E-Mail: documentation@wago.com

We wish to point out that the software and hardware terms as well as the trademarks of companies used and/or mentioned in the present manual are generally protected by trademark or patent.

Table of Contents

1	Notes about this Documentation	5
1.1	Validity of this Documentation.....	5
1.2	Copyright.....	5
1.3	Symbols.....	6
1.4	Number Notation.....	8
1.5	Font Conventions.....	8
2	Important Notes	9
2.1	Legal Bases.....	9
2.1.1	Subject to Changes.....	9
2.1.2	Personnel Qualifications.....	9
2.1.3	Use of the WAGO-I/O-SYSTEM 750 in Compliance with Underlying Provisions.....	9
2.1.4	Technical Condition of Specified Devices.....	10
2.2	Safety Advice (Precautions).....	11
3	Internal Data Bus Structure with Bus Extension	13
4	Device Description	15
4.1	Power Supply.....	15
4.1.1	Isolation.....	15
4.2	View.....	17
4.3	Connectors.....	18
4.3.1	Data Contacts/Internal Bus.....	18
4.3.2	Power Jumper Contacts/Field Supply.....	19
4.3.3	CAGE CLAMP® Connectors.....	20
4.3.4	RJ-45 Connectors.....	21
4.4	Display Elements.....	22
4.5	Operating Elements.....	23
4.6	Schematic Diagram.....	23
4.7	Technical Data.....	24
4.7.1	Device Data.....	24
4.7.2	Supply.....	24
4.7.3	Connection Types.....	24
4.7.4	Communication.....	25
4.7.5	Climatic Environmental Conditions.....	25
4.8	Approvals.....	26
4.9	Standards and Guidelines.....	27
5	Mounting	28
5.1	Mounting Sequence.....	28
5.2	Inserting and Removing Devices.....	29
5.2.1	Inserting the I/O Module.....	29
5.2.2	Removing the I/O Module.....	30
6	Connect Devices	31
6.1	Connecting a Conductor to the CAGE CLAMP®.....	31
6.2	Connecting Cable to RJ-45 Socket.....	32
7	Commissioning	33

8	Use in Hazardous Environments	34
8.1	Marking Configuration Examples	35
8.1.1	Marking for Europe According to ATEX and IEC-Ex	35
8.1.2	Marking for America According to NEC 500	38
8.2	Installation Regulations	39
8.2.1	Special Conditions for Safe Operation of the ATEX and IEC Ex (acc. DEMKO 08 ATEX 142851X and IECEx PTB 07.0064)	40
8.2.2	Special conditions for safe use (ATEX Certificate TÜV 07 ATEX 554086 X)	41
8.2.3	Special conditions for safe use (IEC-Ex Certificate TUN 09.0001 X)	42
8.2.4	Special conditions for safe use (ATEX Certificate DEKRA 11ATEX0203 X)	43
8.2.5	ANSI/ISA 12.12.01	44
	List of Figures	46
	List of Tables	47

1 Notes about this Documentation

Note



Always retain this documentation!

This documentation is part of the product. Therefore, retain the documentation during the entire service life of the product. Pass on the documentation to any subsequent user. In addition, ensure that any supplement to this documentation is included, if necessary.

1.1 Validity of this Documentation

This documentation is only applicable to the I/O module 750-628 (Coupler module for internal data bus extension).

The I/O module 750-628 shall only be installed and operated according to the instructions in this manual and in the manual for the used fieldbus coupler/controller.

NOTICE

Consider power layout of the WAGO-I/O-SYSTEM 750!

In addition to these operating instructions, you will also need the manual for the used fieldbus coupler/controller, which can be downloaded at www.wago.com. There, you can obtain important information including information on electrical isolation, system power and supply specifications.

1.2 Copyright

This Manual, including all figures and illustrations, is copyright-protected. Any further use of this Manual by third parties that violate pertinent copyright provisions is prohibited. Reproduction, translation, electronic and phototechnical filing/archiving (e.g., photocopying) as well as any amendments require the written consent of WAGO Kontakttechnik GmbH & Co. KG, Minden, Germany. Non-observance will involve the right to assert damage claims.

1.3 Symbols

 **DANGER****Personal Injury!**

Indicates a high-risk, imminently hazardous situation which, if not avoided, will result in death or serious injury.

 **DANGER****Personal Injury Caused by Electric Current!**

Indicates a high-risk, imminently hazardous situation which, if not avoided, will result in death or serious injury.

 **WARNING****Personal Injury!**

Indicates a moderate-risk, potentially hazardous situation which, if not avoided, could result in death or serious injury.

 **CAUTION****Personal Injury!**

Indicates a low-risk, potentially hazardous situation which, if not avoided, may result in minor or moderate injury.

NOTICE**Damage to Property!**

Indicates a potentially hazardous situation which, if not avoided, may result in damage to property.

NOTICE**Damage to Property Caused by Electrostatic Discharge (ESD)!**

Indicates a potentially hazardous situation which, if not avoided, may result in damage to property.

Note**Important Note!**

Indicates a potential malfunction which, if not avoided, however, will not result in damage to property.



Information

Additional Information:

Refers to additional information which is not an integral part of this documentation (e.g., the Internet).

1.4 Number Notation

Table 1: Number Notation

Number Code	Example	Note
Decimal	100	Normal notation
Hexadecimal	0x64	C notation
Binary	'100' '0110.0100'	In quotation marks, nibble separated with dots (.)

1.5 Font Conventions

Table 2: Font Conventions

Font Type	Indicates
<i>italic</i>	Names of paths and data files are marked in italic-type. e.g.: <i>C:\Program Files\WAGO Software</i>
Menu	Menu items are marked in bold letters. e.g.: Save
>	A greater-than sign between two names means the selection of a menu item from a menu. e.g.: File > New
Input	Designation of input or optional fields are marked in bold letters, e.g.: Start of measurement range
“Value”	Input or selective values are marked in inverted commas. e.g.: Enter the value “4 mA” under Start of measurement range .
[Button]	Pushbuttons in dialog boxes are marked with bold letters in square brackets. e.g.: [Input]
[Key]	Keys are marked with bold letters in square brackets. e.g.: [F5]

2 Important Notes

This section includes an overall summary of the most important safety requirements and notes that are mentioned in each individual section. To protect your health and prevent damage to devices as well, it is imperative to read and carefully follow the safety guidelines.

2.1 Legal Bases

2.1.1 Subject to Changes

WAGO Kontakttechnik GmbH & Co. KG reserves the right to provide for any alterations or modifications that serve to increase the efficiency of technical progress. WAGO Kontakttechnik GmbH & Co. KG owns all rights arising from the granting of patents or from the legal protection of utility patents. Third-party products are always mentioned without any reference to patent rights. Thus, the existence of such rights cannot be excluded.

2.1.2 Personnel Qualifications

All sequences implemented on WAGO-I/O-SYSTEM 750 devices may only be carried out by electrical specialists with sufficient knowledge in automation. The specialists must be familiar with the current norms and guidelines for the devices and automated environments.

All changes to the coupler or controller should always be carried out by qualified personnel with sufficient skills in PLC programming.

2.1.3 Use of the WAGO-I/O-SYSTEM 750 in Compliance with Underlying Provisions

Fieldbus couplers, fieldbus controllers and I/O modules found in the modular WAGO-I/O-SYSTEM 750 receive digital and analog signals from sensors and transmit them to actuators or higher-level control systems. Using programmable controllers, the signals can also be (pre-) processed.

The devices have been developed for use in an environment that meets the IP20 protection class criteria. Protection against finger injury and solid impurities up to 12.5 mm diameter is assured; protection against water damage is not ensured. Unless otherwise specified, operation of the devices in wet and dusty environments is prohibited.

Operating the WAGO-I/O-SYSTEM 750 devices in home applications without further measures is only permitted if they meet the emission limits (emissions of interference) according to EN 61000-6-3. You will find the relevant information in the section “Device Description” > “Standards and Guidelines” in the manual for the used fieldbus coupler/controller.

Appropriate housing (per 2014/34/EU) is required when operating the WAGO-I/O-SYSTEM 750 in hazardous environments. Please note that a prototype test certificate must be obtained that confirms the correct installation of the system in a housing or switch cabinet.

2.1.4 Technical Condition of Specified Devices

The devices to be supplied ex works are equipped with hardware and software configurations, which meet the individual application requirements. WAGO Kontakttechnik GmbH & Co. KG will be exempted from any liability in case of changes in hardware or software as well as to non-compliant usage of devices.

Please send your request for modified and new hardware or software configurations directly to WAGO Kontakttechnik GmbH & Co. KG.

2.2 Safety Advice (Precautions)

For installing and operating purposes of the relevant device to your system the following safety precautions shall be observed:



DANGER

Do not work on devices while energized!

All power sources to the device shall be switched off prior to performing any installation, repair or maintenance work.

DANGER

Install the device only in appropriate housings, cabinets or in electrical operation rooms!

The WAGO-I/O-SYSTEM 750 and its components are an open system. As such, install the system and its components exclusively in appropriate housings, cabinets or in electrical operation rooms. Allow access to such equipment and fixtures to authorized, qualified staff only by means of specific keys or tools.

NOTICE

Replace defective or damaged devices!

Replace defective or damaged device/module (e.g., in the event of deformed contacts), since the long-term functionality of device/module involved can no longer be ensured.

NOTICE

Protect the components against materials having seeping and insulating properties!

The components are not resistant to materials having seeping and insulating properties such as: aerosols, silicones and triglycerides (found in some hand creams). If you cannot exclude that such materials will appear in the component environment, then install the components in an enclosure being resistant to the above-mentioned materials. Clean tools and materials are imperative for handling devices/modules.

NOTICE

Clean only with permitted materials!

Clean soiled contacts using oil-free compressed air or with ethyl alcohol and leather cloths.

NOTICE**Do not use any contact spray!**

Do not use any contact spray. The spray may impair contact area functionality in connection with contamination.

NOTICE**Do not reverse the polarity of connection lines!**

Avoid reverse polarity of data and power supply lines, as this may damage the devices involved.

**NOTICE****Avoid electrostatic discharge!**

The devices are equipped with electronic components that may be destroyed by electrostatic discharge when touched. Please observe the safety precautions against electrostatic discharge per DIN EN 61340-5-1/-3. When handling the devices, please ensure that environmental factors (personnel, work space and packaging) are properly grounded.

NOTICE**Feed system power supply in parallel!**

The flow of equalizing currents within the bus electronics can destroy the devices. Therefore, connect the system power supply to all supply points of the fieldbus node in parallel. This prevents potential differences and equalizing currents from forming.

NOTICE**Perform insulation tests with direct current (DC)!**

Both the supply voltage and control voltage side are capacitively coupled to the DIN rail. If the modules are mounted on the DIN rail, application of an AC voltage between the two potentials can lead to the destruction of the device.

Use only direct current (DC) for insulation testing.

To avoid destroying the device, discharge the device completely before applying the test voltage again.

3 Internal Data Bus Structure with Bus Extension

With an I/O module 750-627 (end module for bus extension) and one or more I/O modules 750-628 (coupler module for bus extension), a fieldbus node can be divided into max. 11 I/O module blocks (hereinafter referred to as "blocks"). The divided fieldbus nodes still act as a logical unit for the fieldbus coupler/controller. All of the functions of the I/O module system are retained without any changes.

The first block is terminated with an I/O module 750-627 (end module for bus extension). Each subsequent block is started with an I/O module 750-628 (coupler module for bus extension) instead of a fieldbus coupler/controller and terminated with an I/O module 750-600 (end module).

Note



Number of I/O modules independent of bus extension!

The number of total I/O modules permitted in the fieldbus node does not increase by the use of an I/O module for bus extension.

Use an ETHERNET patch cable as a connection cable with the following properties between two blocks:

- Category 5
- Double-insulated shielded twisted pair (STP)
- Cooper
- $4 \times 2 \times 0.25 \text{ mm}^2$

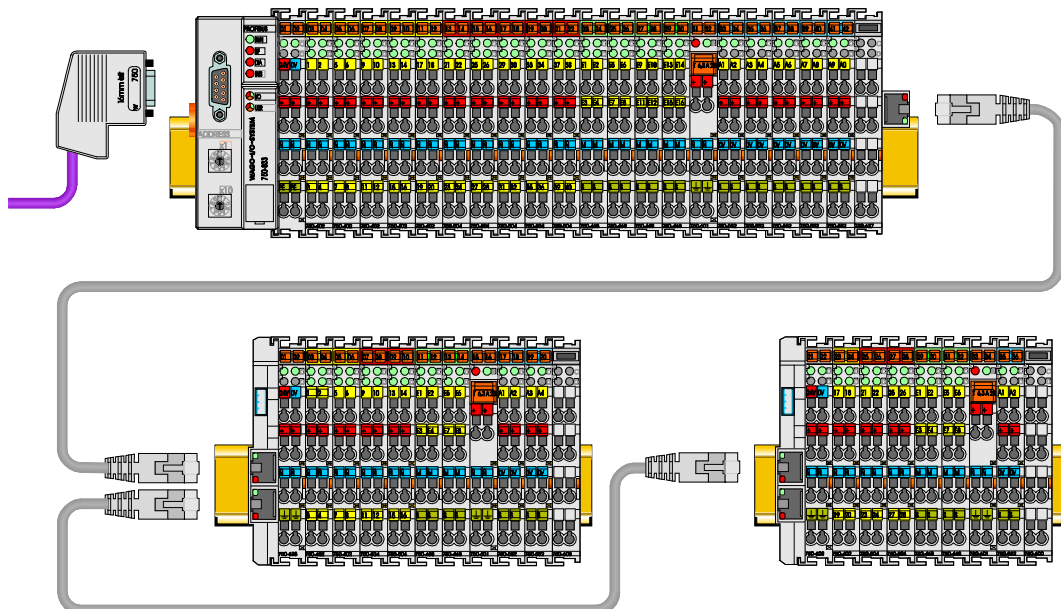

Figure 1: Internal Data Bus Structure with Bus Extension (example)

For the devices as delivered, the cable length between two sub-nodes can be max. 5 meters. Many fieldbus couplers/controllers can be configured, so that the permitted cable length can be increased to max. 10 meters.

This setting can be made using the "WAGO Extension Setting Tool" (759-314), which can be downloaded at www.wago.com at no cost.

Note



Note the maximum total cable length of 70 meters!

The length of all connection cables cannot exceed 70 meters.

The maximum cable length permitted cannot be increased for the following fieldbus couplers/controllers:

Item No.	Name
750-300	II/O-LIGHTBUS Fieldbus Coupler
750-301	PROFIBUS Fieldbus Coupler
750-304	INTERBUS Fieldbus Coupler
750-305	CAL Fieldbus Coupler
750-309	LON Fieldbus Coupler
750-310	CC-LINK Fieldbus Coupler
750-312	MODBUS Fieldbus Coupler, RS-485
750-313	SDS Fieldbus Coupler
750-314	MODBUS Fieldbus Coupler, RS-232
750-315	MODBUS Fieldbus Coupler, RS-485
750-316	MODBUS Fieldbus Coupler, RS-232
750-327	CANopen Fieldbus Coupler
750-331	PROFIBUS Fieldbus Coupler
750-339	FireWire Fieldbus Coupler
750-804	INTERBUS Fieldbus Controller
750-812	MODBUS Fieldbus Controller, RS-485
750-814	MODBUS Fieldbus Controller, RS-232
750-815	MODBUS Fieldbus Controller, RS-485
750-816	MODBUS Fieldbus Controller, RS-232

The above table does not include all versions of the fieldbus couplers/controllers. In contrast to standard items, some specific variants may indeed support a configuration change. Corresponding information is given in the documentation for the specific fieldbus coupler/controller.

4 Device Description

The I/O module 750-628 (coupler module for bus extension) replaces the fieldbus coupler/controller at a block. More information on the basic structure of a fieldbus node is available in Section "Internal Data Bus Structure with Bus Extension".

The I/O module has a switch with which a terminating resistor can be connected. Use in the last, as well as in a block in the middle of a fieldbus node is possible. To connect with the blocks, the I/O module has two RJ-45 sockets.

Two diagnostic LEDs indicate the state of the system and field supply voltage for the relevant block. The two LEDs of an RJ-45 socket indicate error-free communication with the adjacent blocks. The supply voltage for the field side and the internal system can be input separately. Both levels are electrically isolated from each other.

NOTICE

Do not exceed maximum current via power jumper contacts!

The maximum current to flow through the power jumper contacts is 10 A. Greater currents can damage the contacts.

When configuring your system, ensure that this current is not exceeded. If exceeded, insert an additional supply module.

4.1 Power Supply

4.1.1 Isolation

Within the fieldbus node, there are three electrically isolated potentials:

- Electrically isolated fieldbus interface via transformer
- Electronics of the fieldbus couplers/controllers and the I/O modules (internal bus)
- All I/O modules have an electrical isolation between the electronics (internal bus, logic) and the field electronics. Some digital and analog input modules have each channel electrically isolated, please see catalog.

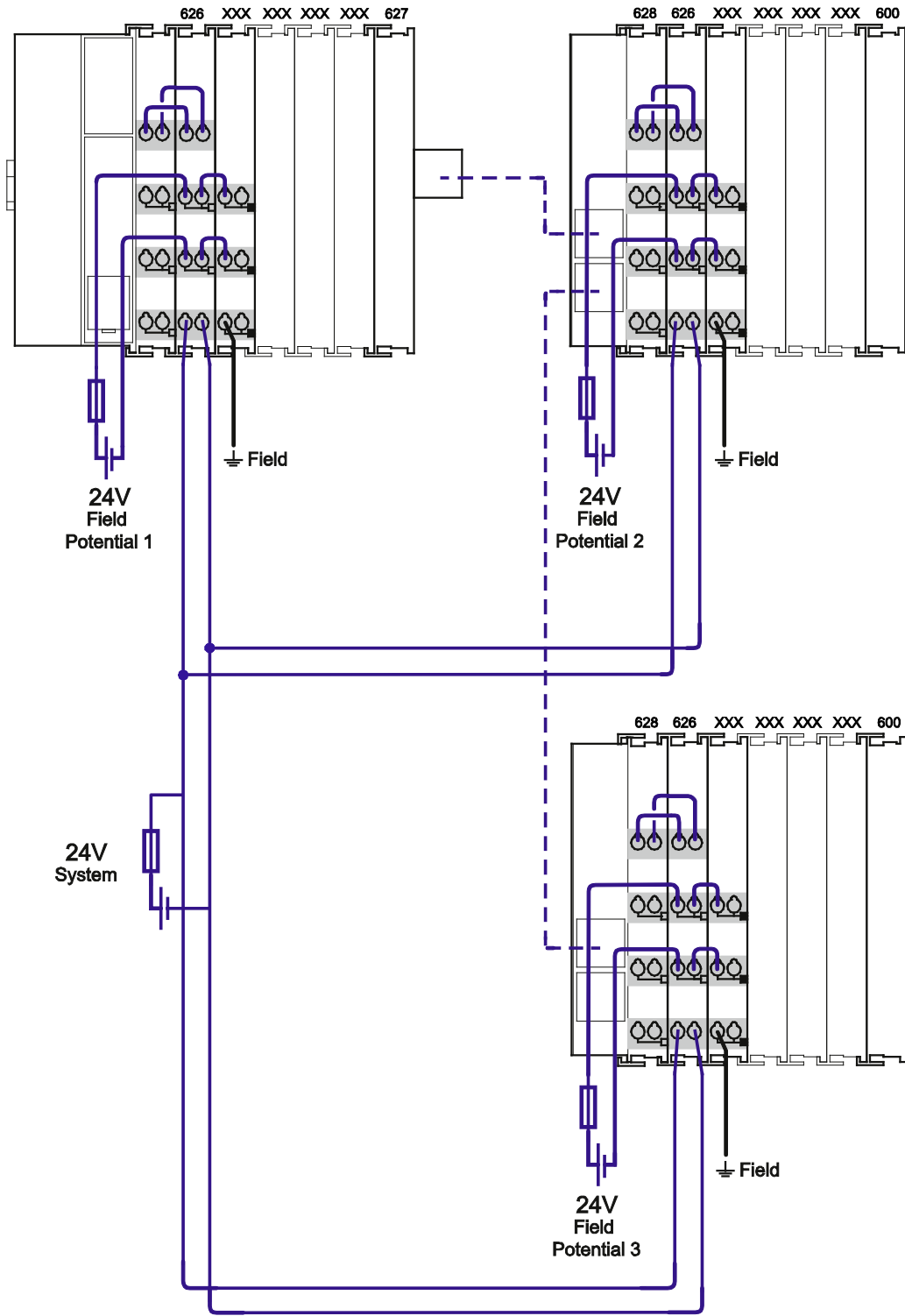

Figure 2: Isolation Coupler Module (Example)

4.2 View

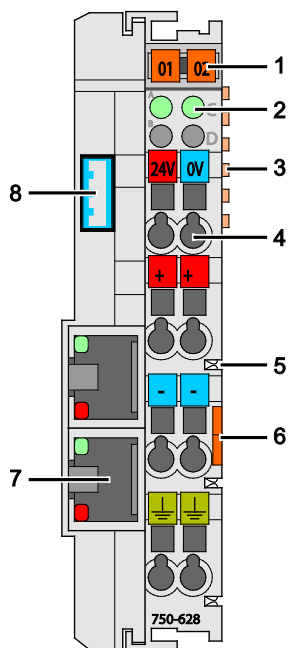

Figure 3: View

Table 3: Legend for Figure “View”

Pos.	Description	Details See Section
1	Marking possibility with Mini-WSB	---
2	Status-LEDs	“Device Description” > “Display Elements”
3	Data contacts	“Device Description” > “Connectors”
4	CAGE CLAMP®-connectors	“Device Description” > “Connectors”
5	Power jumper contacts	“Device Description” > “Connectors”
6	Release tab	“Mounting” > “Inserting and Removing Devices”
7	Bus connection (RJ-45)	<ul style="list-style-type: none"> “Device Description” > “Display Elements” “Device Description” > “Connectors”
8	Terminating resistor	“Device Description” > “Operating Elements”

4.3 Connectors

4.3.1 Data Contacts/Internal Bus

Communication between the fieldbus coupler/controller and the I/O modules as well as the system supply of the I/O modules is carried out via the internal bus. It is comprised of 6 data contacts, which are available as self-cleaning gold spring contacts.

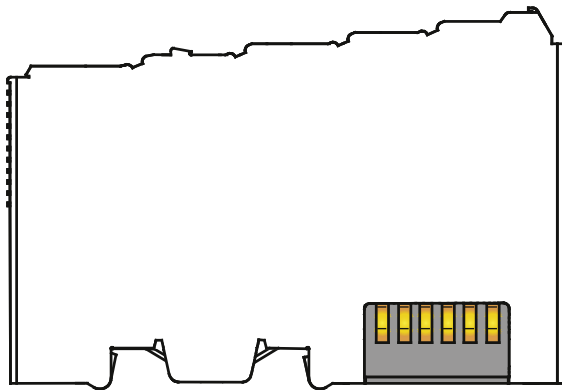

Figure 4: Data Contacts

NOTICE

Do not place the I/O modules on the gold spring contacts!

Do not place the I/O modules on the gold spring contacts in order to avoid soiling or scratching!

NOTICE



Ensure that the environment is well grounded!

The devices are equipped with electronic components that may be destroyed by electrostatic discharge. When handling the devices, ensure that the environment (persons, workplace and packing) is well grounded. Avoid touching conductive components, e.g. data contacts.

4.3.2 Power Jumper Contacts/Field Supply

The Coupler module for internal data bus extension 750-628 is equipped with 3 self-cleaning power contacts for transferring of the field-side power supply to down-circuit I/O modules. These contacts are designed as spring contacts.

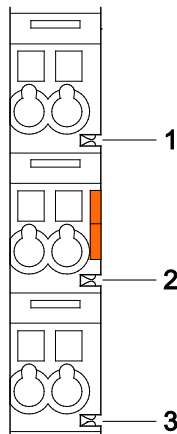

Figure 5: Power Jumper Contacts

Table 4: Legend for Figure “Power Jumper Contacts”

Contact	Type	Function
1	Spring contact	Potential transmission (U_V) for field supply
2	Spring contact	Potential transmission (0 V) for field supply
3	Spring contact	Potential transmission (ground) for field supply

NOTICE

Do not exceed maximum current via power jumper contacts!

The maximum current to flow through the power jumper contacts is 10 A. Greater currents can damage the contacts.

When configuring your system, ensure that this current is not exceeded. If exceeded, insert an additional supply module.

4.3.3 CAGE CLAMP® Connectors

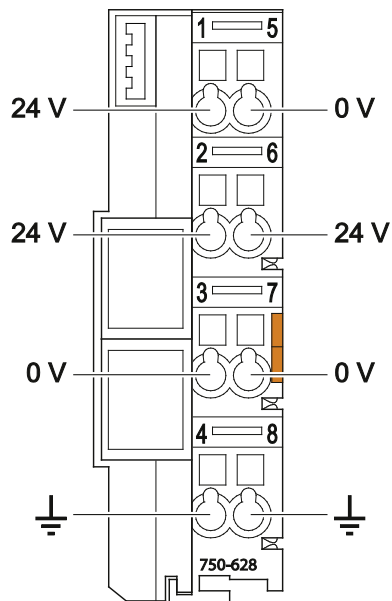

Figure 6: CAGE CLAMP® Connectors

Table 5: Legend for Figure „CAGE CLAMP® Connectors“

Designation	Connector	Function
24 V	1	System supply voltage: 24 VDC
0 V	5	System supply voltage: 0 V
24 V	2	Field supply voltage: 24 V
	6	Field supply voltage: 24 V
0 V	3	Field supply voltage: 0 V
	7	Field supply voltage: 0 V
Ground	4	Field supply voltage: ground
	8	Field supply voltage: ground

4.3.4 RJ-45 Connectors

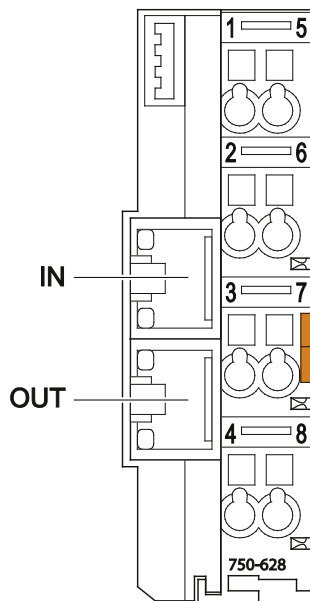

Figure 7: Connectors

Table 6: Legend for Figure „Connectors“

Designation	Connector	Function
IN	RJ-45 with LED	Bus connection, input (RJ-45)
OUT	RJ-45 with LED	Bus connection, output (RJ-45)

4.4 Display Elements

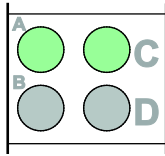

Figure 8: Display Elements – Power Supply

Table 7: Legend for Figure „Display Elements – Power Supply“

Designation	LED	State	Function
Status of operating voltage – system	A	Off	No 24 VDC system supply voltage.
		Green	24 VDC system supply voltage.
Status of operating voltage – power jumper contacts	C	Off	No 24 VDC voltage supply via power jumper contacts.
		Green	24 VDC voltage supply via power jumper contacts.

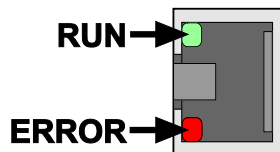

Figure 9: Display Elements – Bus Connection

Table 8: Legend for Figure „Display Elements – Bus Connection“

Designation	LED	State	Function
RUN	Green	Off	No Communication
		On	Communication is available
ERROR	Red	Off	Communication is available
		On	No Communication

4.5 Operating Elements

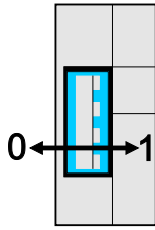

Figure 10: Operating Elements

Table 9: Legend for Figure “Operating Elements “

Designation	State	Function
Terminating resistor	0	Terminating resistor is switched off, I/O module is not last coupler module
	1	Terminating resistor is switched on, I/O module is last coupler module

4.6 Schematic Diagram

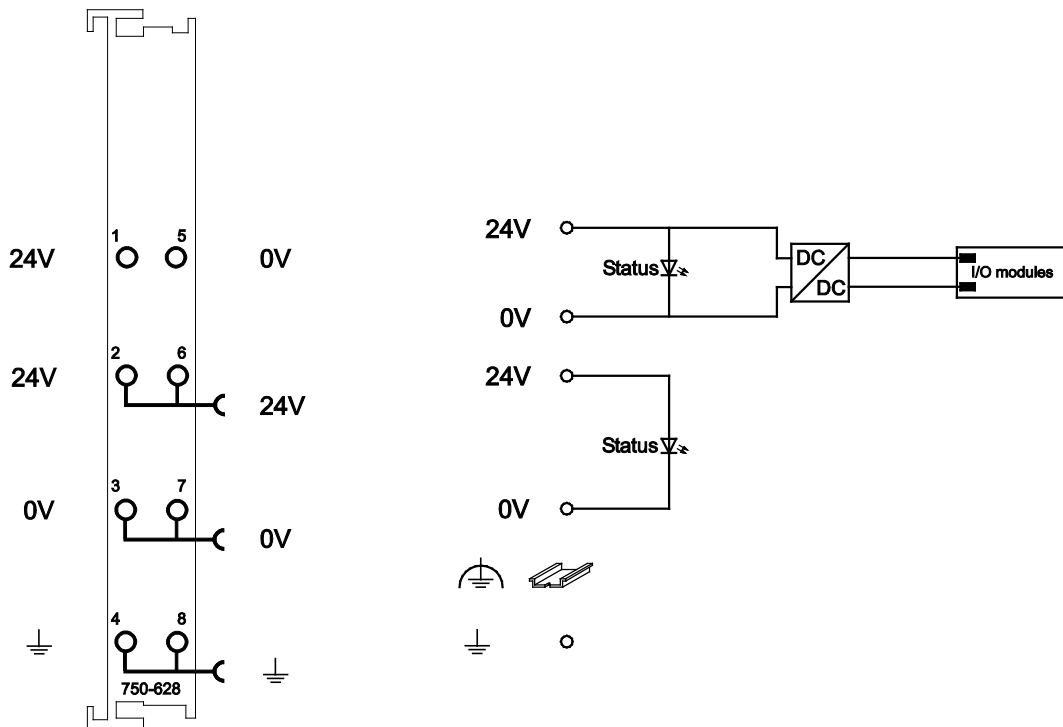

Figure 11: Schematic Diagram

4.7 Technical Data

4.7.1 Device Data

Table 10: Technical Data – Device

Width	25 mm
Height (from upper edge of 35 DIN rail)	64 mm
Depth	100 mm
Weight	Approx. 70 g
Degree of protection	IP20

4.7.2 Supply

Table 11: Technical Data – Supply

System supply	
Input voltage supply	DC 24 V (-15 % ... +20 %)
Input current consumption _{max.}	200 mA
Input inrush current	2,5 x continuous current
Voltage output	DC 5 V
Current output _{max.}	400 mA
Field supply	
Voltage	DC 24 V (-25 % ... +30 %)
Current consumption _{max.}	DC 10 A
Current output _{max.}	DC 10 A
Isolation	
System/supply	500 V

4.7.3 Connection Types

Table 12: Technical Data – Connection Types: Interfaces

Number of interfaces	2
Bus connection	RJ-45 socket (input and output)

Table 13: Technical Data – Connection Types: Field Wiring

Wire connection	CAGE CLAMP®
Cross section	0,25 mm ² ... 2,5 mm ² / AWG 24 ... 14
Stripped lengths	8 mm ... 9 mm / 0,33 in

Table 14: Technical Data – Connection Types: Power Jumper Contacts

Power jumper contacts	Spring contacts, self-cleaning
Voltage drop at I _{max.}	< 1 V at 64 I/O modules

Table 15: Technical Data – Connection Types: Internal Data Bus

Data contacts	Slide contacts, self-cleaning
---------------	-------------------------------

4.7.4 Communication

Table 16: Technical Data – Communication

Number of I/O modules of each node max.	Depending on the used coupler/controller
Number of I/O modules of each coupler module max.	Hardware/software version [item number] < XXXX0103... : 40
	Hardware/software version [item number] ≥ XXXX0103... : 64
Number of coupler modules max.	10
Number of partial nodes max.	11
Distance between two components (end module and coupler module or coupler module and coupler module) max.	5 m (10 m with capable copplers/controllers, see table in chapter “Module Bus Structure”)
Distance between all components (complete node) max.	70 m
Transmission medium	Shielded copper wire (Ethernet patch cable) 4 x 2 x 0.25 mm ² , twisted pair, double shielding STP (Shielded Twisted-Pair)

4.7.5 Climatic Environmental Conditions

Table 17: Technical Data – Climatic Environmental Conditions

Operating temperature range	0 °C ... 55 °C
Storage temperature range	-25 °C ... +85 °C
Relative humidity without condensation	Max. 95 %
Resistance to harmful substances	Acc. to IEC 60068-2-42 and IEC 60068-2-43
Maximum pollutant concentration at relative humidity < 75 %	SO ₂ ≤ 25 ppm H ₂ S ≤ 10 ppm
Special conditions	Ensure that additional measures for components are taken, which are used in an environment involving: – dust, caustic vapors or gases – ionizing radiation

4.8 Approvals



Information

More information about approvals.

Detailed references to the approvals are listed in the document “Overview Approvals **WAGO-I/O-SYSTEM 750**”, which you can find via the internet under: www.wago.com > SERVICES > DOWNLOADS > Additional documentation and information on automation products > WAGO-I/O-SYSTEM 750 > System Description.

The following approvals have been granted to 750-628 I/O modules:



Conformity Marking



cUL_{us}

UL508



Korea Certification

MSIP-REM-W43-IDE750

The following Ex approvals have been granted to 750-628 I/O modules:



DEKRA 11 ATEX 0203 X

II 3 G Ex nA IIC T4 Gc

The following ship approvals have been granted to 750-628 I/O modules:



Federal Maritime and Hydrographic Agency



BV (Bureau Veritas)



GL (Germanischer Lloyd)

Cat. A, B, C, D (EMC 1)



RINA (Registro Italiano Navale)

4.9 Standards and Guidelines

All variations of 750-628 I/O modules meet the following requirements on emission and immunity of interference:

EMC CE-Emission of interference	EN 61000-6-4
EMC CE-Immunity to interference	EN 61000-6-2
ATEX guideline	EN 60079-0 and to EN 60079-15

5 Mounting

5.1 Mounting Sequence

Fieldbus couplers/controllers and I/O modules of the WAGO-I/O-SYSTEM 750/753 are snapped directly on a carrier rail in accordance with the European standard EN 50022 (DIN 35).

The reliable positioning and connection is made using a tongue and groove system. Due to the automatic locking, the individual devices are securely seated on the rail after installation.

Starting with the fieldbus coupler/controller, the I/O modules are mounted adjacent to each other according to the project design. Errors in the design of the node in terms of the potential groups (connection via the power contacts) are recognized, as the I/O modules with power contacts (blade contacts) cannot be linked to I/O modules with fewer power contacts.

CAUTION

Risk of injury due to sharp-edged blade contacts!

The blade contacts are sharp-edged. Handle the I/O module carefully to prevent injury.

NOTICE

Insert I/O modules only from the proper direction!

All I/O modules feature grooves for power jumper contacts on the right side. For some I/O modules, the grooves are closed on the top. Therefore, I/O modules featuring a power jumper contact on the left side cannot be snapped from the top. This mechanical coding helps to avoid configuration errors, which may destroy the I/O modules. Therefore, insert I/O modules only from the right and from the top.

Note



Don't forget the bus end module!

Always plug a bus end module (750-600) onto the end of the fieldbus node! You must always use a bus end module at all fieldbus nodes with WAGO-I/O-SYSTEM 750 fieldbus couplers/controllers to guarantee proper data transfer.

5.2 Inserting and Removing Devices

NOTICE

Perform work on devices only if they are de-energized!

Working on energized devices can damage them. Therefore, turn off the power supply before working on the devices.

5.2.1 Inserting the I/O Module

1. Position the I/O module so that the tongue and groove joints to the fieldbus coupler/controller or to the previous or possibly subsequent I/O module are engaged.

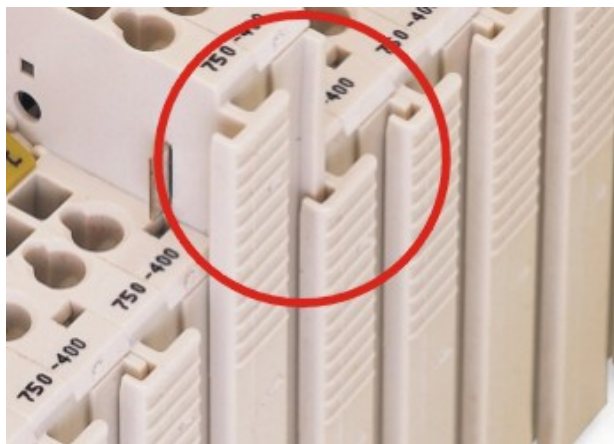

Figure 12: Insert I/O Module (Example)

2. Press the I/O module into the assembly until the I/O module snaps into the carrier rail.

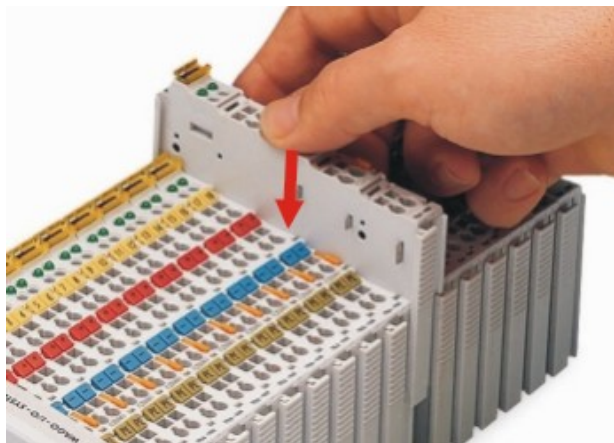

Figure 13: Snap the I/O Module into Place (Example)

With the I/O module snapped in place, the electrical connections for the data contacts and power jumper contacts (if any) to the fieldbus coupler/controller or to the previous or possibly subsequent I/O module are established.

5.2.2 Removing the I/O Module

1. Remove the I/O module from the assembly by pulling the release tab.

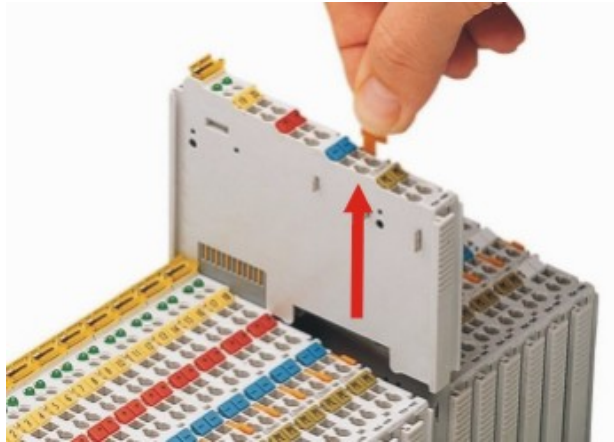

Figure 14: Removing the I/O Module (Example)

Electrical connections for data or power jumper contacts are disconnected when removing the I/O module.

6 Connect Devices

NOTICE

Feed system power supply in parallel!

The flow of equalizing currents within the bus electronics can destroy the devices. Therefore, connect the system power supply to all supply points of the fieldbus node in parallel. This prevents potential differences and equalizing currents from forming.

6.1 Connecting a Conductor to the CAGE CLAMP®

The WAGO CAGE CLAMP® connection is appropriate for solid, stranded and finely stranded conductors.



Note

Only connect one conductor to each CAGE CLAMP®!

Only one conductor may be connected to each CAGE CLAMP®.

Do not connect more than one conductor at one single connection!

If more than one conductor must be routed to one connection, these must be connected in an up-circuit wiring assembly, for example using WAGO feed-through terminals.

1. For opening the CAGE CLAMP® insert the actuating tool into the opening above the connection.
2. Insert the conductor into the corresponding connection opening.
3. For closing the CAGE CLAMP® simply remove the tool. The conductor is now clamped firmly in place.

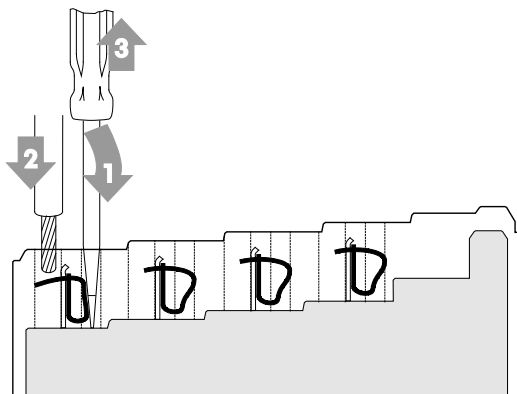

Figure 15: Connecting a Conductor to a CAGE CLAMP®

6.2 Connecting Cable to RJ-45 Socket

1. Connect the cable for bus extension from the previous block to the top RJ-45 socket (IN) of the I/O module.

To connect the block to another block:

2. Connect the cable for bus extension of the block currently being considered to the bottom RJ-45 socket (OUT) of the I/O module.
3. Connect the cable for bus extension to the top RJ-45 socket (IN) of the I/O module of the next block.

Note



Connection to the I/O module!

Up to 40 I/O modules can be connected to an I/O module 750-628 with hardware/software version [series item number] < XXXX-0103 and up to 64 I/O modules can be connected to an I/O module 750-628 with hardware/software version [series item number] ≥ XXXX-0103.

7 Commissioning

DANGER

Caution in case of failure of the I/O module!

If the I/O module 750-628 fails, communication is interrupted to the subsequent I/O module blocks. Make sure that people or equipment are not placed at risk if the I/O module 750-628 fails.

DANGER

Switch on the terminating resistor at the last I/O module 750-628 only!

Only switch on the terminating resistor at the I/O module 750-628 located in the last of the I/O module blocks of the split fieldbus node. If the terminating resistor of another I/O module 750-628 in the fieldbus node is activated, faulty functions of the fieldbus node may occur (e.g., accidental connection of outputs).

If the current block represents the last block of the fieldbus node:

1. Switch on the terminating resistor.
2. Flip the switch to the right.

If the current block is connected to another block, i.e., not the last block in the fieldbus node:

1. Switch off the terminating resistor.
2. Flip the switch to the left.

The terminating resistor is activated.

8 Use in Hazardous Environments

The **WAGO-I/O-SYSTEM 750** (electrical equipment) is designed for use in Zone 2 hazardous areas.

The following sections include both the general identification of components (devices) and the installation regulations to be observed. The individual subsections of the “Installation Regulations” section must be taken into account if the I/O module has the required approval or is subject to the range of application of the ATEX directive.

8.1 Marking Configuration Examples

8.1.1 Marking for Europe According to ATEX and IEC-Ex

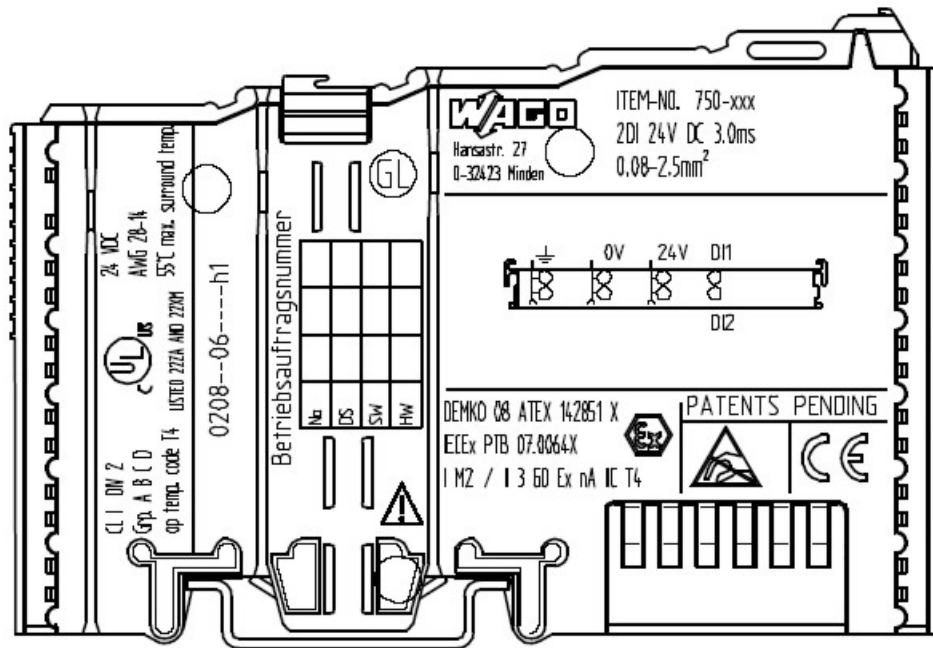

Figure 16: Side Marking Example for ATEX and IEC Ex Approved I/O Modules According to CENELEC and IEC

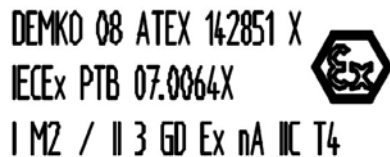

Figure 17: Printing Text Detail – Marking Example for ATEX and IEC Ex Approved I/O Modules According to CENELEC and IEC

Table 18: Description of Marking Example for ATEX and IEC Ex Approved I/O Modules According to CENELEC and IEC

Marking	Description
DEMKO 08 ATEX 142851 X IECEX PTB 07.0064X	Approval body and/or number of the examination certificate
I M2 / II 3 GD	Explosion protection group and Unit category
Ex nA	Type of ignition and extended identification
IIC	Explosion protection group
T4	Temperature class

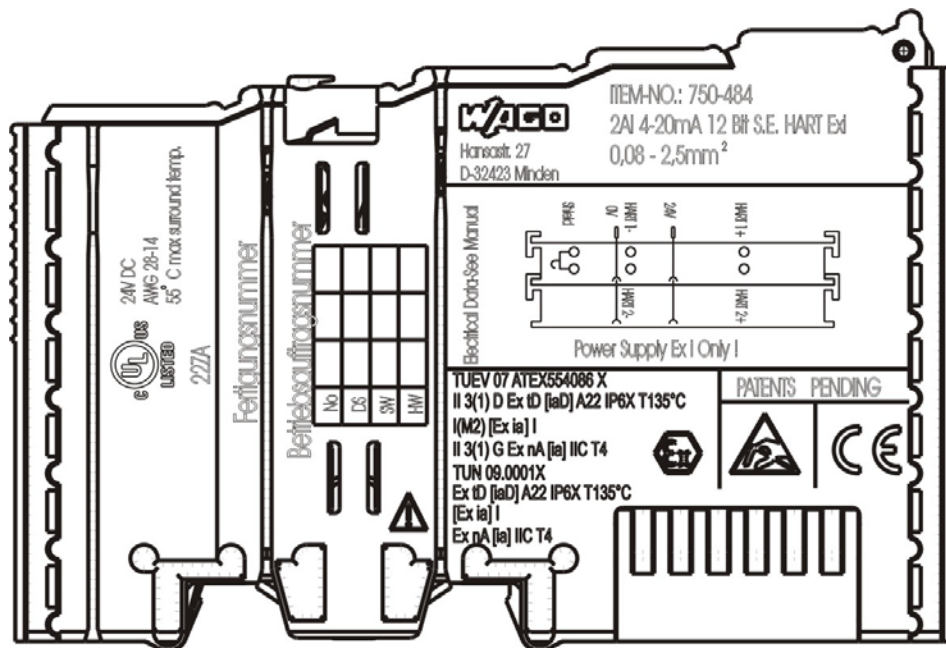

Figure 18: Side Marking Example for Ex i and IEC Ex i Approved I/O Modules According to CENELEC and IEC

TUEV 07 ATEX554086 X
II 3(1) D Ex tD [iaD] A22 IP6X T135°C
I(M2) [Ex ia] I
II 3(1) G Ex nA [ia] IIC T4
TUN 09.0001X
Ex tD [iaD] A22 IP6X T135°C
[Ex ia] I
Ex nA [ia] IIC T4



Figure 19: Text Detail – Marking Example for Ex i and IEC Ex i Approved I/O Modules According to CENELEC and IEC

Table 19: Description of Marking Example for Ex i and IEC Ex i Approved I/O Modules According to CENELEC and IEC

Marking	Description
TÜV 07 ATEX 554086 X TUN 09.0001X	Approving authority or certificate numbers
Dust	
II	Device group: All except mining
3(1)D	Device category: Zone 22 device (Zone 20 subunit)
Ex	Explosion protection mark
tD	Protection by enclosure
[iaD]	Approved in accordance with "Dust intrinsic safety" standard
A22	Surface temperature determined according to Procedure A, use in Zone 22
IP6X	Dust-tight (totally protected against dust)
T 135°C	Max. surface temp. of the enclosure (no dust bin)
Mining	
I	Device group: Mining
(M2)	Device category: High degree of safety
[Ex ia]	Explosion protection: Mark with category of type of protection intrinsic safety: Even safe when two errors occur
I	Device group: Mining
Gases	
II	Device group: All except mining
3(1)G	Device category: Zone 2 device (Zone 0 subunit)
Ex	Explosion protection mark
nA	Type of protection: Non-sparking operating equipment
[ia]	Category of type of protection intrinsic safety: Even safe when two errors occur
IIC	Explosion Group
T4	Temperature class: Max. surface temperature 135°C

8.1.2 Marking for America According to NEC 500

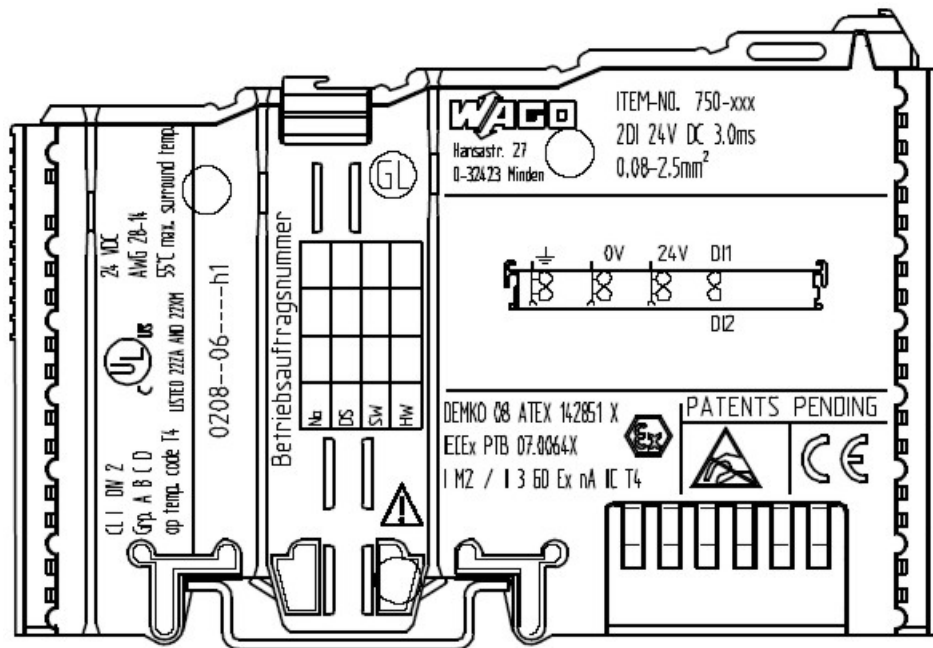

Figure 20: Side Marking Example for I/O Modules According to NEC 500

CL 1 DIV 2
Grp. A B C D
op temp. code T4 LISTED 22ZA AND 22XM

Figure 21: Text Detail – Marking Example for I/O Modules According to NEC 500

Table 20: Description of Marking Example for I/O Modules According to NEC 500

Marking	Description
CL 1	Explosion protection group (condition of use category)
DIV 2	Area of application (zone)
Grp. ABCD	Explosion group (gas group)
Optemp code T4	Temperature class

8.2 Installation Regulations

In the **Federal Republic of Germany**, various national regulations for the installation in explosive areas must be taken into consideration. The basis for this forms the working reliability regulation, which is the national conversion of the European guideline 99/92/E6. They are complemented by the installation regulation EN 60079-14. The following are excerpts from additional VDE regulations:

Table 21: VDE Installation Regulations in Germany

DIN VDE 0100	Installation in power plants with rated voltages up to 1000 V
DIN VDE 0101	Installation in power plants with rated voltages above 1 kV
DIN VDE 0800	Installation and operation in telecommunication plants including information processing equipment
DIN VDE 0185	lightning protection systems

The **USA** and **Canada** have their own regulations. The following are excerpts from these regulations:

Table 22: Installation Regulations in USA and Canada

NFPA 70	National Electrical Code Art. 500 Hazardous Locations
ANSI/ISA-RP 12.6-1987	Recommended Practice
C22.1	Canadian Electrical Code

NOTICE

Notice the following points

When using the **WAGO-I/O SYSTEM 750** (electrical operation) with Ex approval, the following points are mandatory:

8.2.1 Special Conditions for Safe Operation of the ATEX and IEC Ex (acc. DEMKO 08 ATEX 142851X and IECEx PTB 07.0064)

The fieldbus-independent I/O modules of the WAGO-I/O-SYSTEM 750-.../...-... must be installed in an environment with degree of pollution 2 or better. In the final application, the I/O modules must be mounted in an enclosure with IP 54 degree of protection at a minimum with the following exceptions:

- I/O modules 750-440, 750-609 and 750-611 must be installed in an IP 64 minimum enclosure.
- I/O module 750-540 must be installed in an IP 64 minimum enclosure for 230 V AC applications.
- I/O module 750-440 may be used up to max. 120 V AC.

When used in the presence of combustible dust, all devices and the enclosure shall be fully tested and assessed in compliance with the requirements of IEC 61241-0:2004 and IEC 61241-1:2004.

When used in mining applications the equipment shall be installed in a suitable enclosure according to EN 60079-0:2006 and EN 60079-1:2007.

I/O modules fieldbus plugs or fuses may only be installed, added, removed or replaced when the system and field supply is switched off or the area exhibits no explosive atmosphere.

DIP switches, coding switches and potentiometers that are connected to the I/O module may only be operated if an explosive atmosphere can be ruled out.

I/O module 750-642 may only be used in conjunction with antenna 758-910 with a max. cable length of 2.5 m.

To exceed the rated voltage no more than 40%, the supply connections must have transient protection.

The permissible ambient temperature range is 0 °C to +55 °C.

8.2.2 Special conditions for safe use (ATEX Certificate TÜV 07 ATEX 554086 X)

1. For use as Gc- or Dc-apparatus (in zone 2 or 22) the field bus independent I/O modules WAGO-I/O-SYSTEM 750-*** shall be erected in an enclosure that fulfils the requirements of the applicable standards (see the marking) EN 60079-0, EN 60079-11, EN 60079-15, EN 61241-0 and EN 61241-1. For use as group I, electrical apparatus M2, the apparatus shall be erected in an enclosure that ensures a sufficient protection according to EN 60079-0 and EN 60079-1 and the degree of protection IP64. The compliance of these requirements and the correct installation into an enclosure or a control cabinet of the devices shall be certified by an ExNB.
2. If the interface circuits are operated without the field bus coupler station type 750-3../...-... (DEMKO 08 ATEX 142851 X), measures must be taken outside of the device so that the rating voltage is not being exceeded of more than 40% because of transient disturbances.
3. DIP-switches, binary-switches and potentiometers, connected to the module may only be actuated when explosive atmosphere can be excluded.
4. The connecting and disconnecting of the non-intrinsically safe circuits is only permitted during installation, for maintenance or for repair purposes. The temporal coincidence of explosion hazardous atmosphere and installation, maintenance resp. repair purposes shall be excluded. This is although and in particular valid for the interfaces “CF-Card”, “USB”, “Fieldbus connection“, “Configuration and programming interface“, “antenna socket“, “D-Sub“ and the “Ethernet interface“. These interfaces are not energy limited or intrinsically safe circuits. An operating of those circuits is in the behalf of the operator.
5. For the types 750-606, 750-625/000-001, 750-487/003-000, 750-484 and 750-633 the following shall be considered: The interface circuits shall be limited to overvoltage category I/II/III (non mains/mains circuits) as defined in EN 60664-1.
6. For the type 750-601 the following shall be considered: Do not remove or replace the fuse when the apparatus is energized.
7. The ambient temperature range is: $0^{\circ}\text{C} \leq T_a \leq +55^{\circ}\text{C}$ (for extended details please note certificate).

8.2.3 Special conditions for safe use (IEC-Ex Certificate TUN 09.0001 X)

1. For use as Dc- or Gc-apparatus (in zone 2 or 22) the fieldbus independent I/O modules WAGO-I/O-SYSTEM 750-*** shall be erected in an enclosure that fulfils the requirements of the applicable standards (see the marking) IEC 60079-0, IEC 60079-11, IEC 60079-15, IEC 61241-0 and IEC 61241-1. For use as group I, electrical apparatus M2, the apparatus shall be erected in an enclosure that ensures a sufficient protection according to IEC 60079-0 and IEC 60079-1 and the degree of protection IP64. The compliance of these requirements and the correct installation into an enclosure or a control cabinet of the devices shall be certified by an ExCB.
2. Measures have to be taken outside of the device that the rating voltage is not being exceeded of more than 40% because of transient disturbances.
3. DIP-switches, binary-switches and potentiometers, connected to the module may only be actuated when explosive atmosphere can be excluded.
4. The connecting and disconnecting of the non-intrinsically safe circuits is only permitted during installation, for maintenance or for repair purposes. The temporal coincidence of explosion hazardous atmosphere and installation, maintenance resp. repair purposes shall be excluded. This is although and in particular valid for the interfaces "CF-Card", "USB", "Fieldbus connection", "Configuration and programming interface", "antenna socket", "D-Sub" and the "Ethernet interface". These interfaces are not energy limited or intrinsically safe circuits. An operating of those circuits is in the behalf of the operator.
5. For the types 750-606, 750-625/000-001, 750-487/003-000, 750-484 and 750-633 the following shall be considered: The interface circuits shall be limited to overvoltage category I/II/III (non mains/mains circuits) as defined in IEC 60664-1.
6. For the type 750-601 the following shall be considered: Do not remove or replace the fuse when the apparatus is energized.
7. The ambient temperature range is: $0^{\circ}\text{C} \leq T_a \leq +55^{\circ}\text{C}$ (For extensions please see the certificate).

8.2.4 Special conditions for safe use (ATEX Certificate DEKRA 11ATEX0203 X)

1. The components shall be installed in a suitable enclosure providing a degree of protection of at least IP54 according to EN 60529, taking into account the environmental conditions under which the equipment will be used.
2. When the temperature under rated conditions exceeds 70 °C at the cable or conduit entry point, or 80 °C at the branching point of the conductors, the temperature specification of the selected cable shall be in compliance with the actual measured temperature values.
3. Provisions shall be made to prevent the rated voltages from being exceeded by transient disturbances of more than 40 %.
4. Components may only be removed or inserted when the system supply and the field supply are switched off, or when the location is known to be non-hazardous.
5. Fieldbus connectors may only be disconnected or connected when the system supply is switched off, or when the location is known to be non-hazardous.
6. The fuses, present in de the system modules 750-6xx may only be replaced when the supply is switched off, or when the location is known to be non-hazardous.
7. Address selectors and ID switches may only be adjusted when the system supply is switched off, or when the location is known to be non-hazardous.
8. The ambient temperature range is: $0^{\circ}\text{C} \leq T_a \leq +55^{\circ}\text{C}$.

8.2.5 ANSI/ISA 12.12.01

This equipment is suitable for use in Class I, Division 2, Groups A, B, C, D or non-hazardous locations only.

This equipment is to be fitted within tool-secured enclosures only.

WARNING

Explosion hazard!

Explosion hazard - substitution of components may impair suitability for Class I, Div. 2.

WARNING

Disconnect device when power is off and only in a non-hazardous area!

Do not disconnect equipment unless power has been switched off or the area is known to be non-hazardous near each operator accessible connector and fuse holder." When a fuse is provided, the following information shall be provided: "A switch suitable for the location where the equipment is installed shall be provided to remove the power from the fuse."

For devices with ETHERNET connectors:

"Only for use in LAN, not for connection to telecommunication circuits".

WARNING

Use only with antenna module 758-910!

Use Module 750-642 only with antenna module 758-910.

For Couplers/Controllers and Economy bus modules only: "The configuration Interface Service connector is for temporary connection only. Do not connect or disconnect unless the area is known to be nonhazardous. Connection or disconnection in an explosive atmosphere could result in an explosion.

WARNING

Devices containing fuses must not be fitted into circuits subject to over loads!

Devices containing fuses must not be fitted into circuits subject to over loads, e.g. motor circuits!

 **WARNING**

For devices equipped with SD card slots: Insert or remove the SD cards unless the area known to be free of ignitable concentrations of flammable gases or vapors!

Do not connect or disconnect SD-Card while circuit is live unless the area is known to be free of ignitable concentrations of flammable gases or vapors.

 **Information**

Additional Information

Proof of certification is available on request.

Also take note of the information given on the operating and assembly instructions.

The manual, containing these special conditions for safe use, must be readily available to the user.

List of Figures

Figure 1: Internal Data Bus Structure with Bus Extension (example)	13
Figure 2: Isolation Coupler Module (Example)	16
Figure 3: View	17
Figure 4: Data Contacts	18
Figure 5: Power Jumper Contacts	19
Figure 6: CAGE CLAMP [®] Connectors	20
Figure 7: Connectors	21
Figure 8: Display Elements – Power Supply	22
Figure 9: Display Elements – Bus Connection	22
Figure 10: Operating Elements	23
Figure 11: Schematic Diagram	23
Figure 12: Insert I/O Module (Example)	29
Figure 13: Snap the I/O Module into Place (Example)	29
Figure 14: Removing the I/O Module (Example)	30
Figure 15: Connecting a Conductor to a CAGE CLAMP [®]	31
Figure 16: Side Marking Example for ATEX and IEC Ex Approved I/O Modules According to CENELEC and IEC	35
Figure 17: Printing Text Detail – Marking Example for ATEX and IEC Ex Approved I/O Modules According to CENELEC and IEC	35
Figure 18: Side Marking Example for Ex i and IEC Ex i Approved I/O Modules According to CENELEC and IEC	36
Figure 19: Text Detail – Marking Example for Ex i and IEC Ex i Approved I/O Modules According to CENELEC and IEC	36
Figure 20: Side Marking Example for I/O Modules According to NEC 500	38
Figure 21: Text Detail – Marking Example for I/O Modules According to NEC 500	38

List of Tables

Table 1: Number Notation.....	8
Table 2: Font Conventions	8
Table 3: Legend for Figure “View”	17
Table 4: Legend for Figure “Power Jumper Contacts”	19
Table 5: Legend for Figure „CAGE CLAMP® Connectors“	20
Table 6: Legend for Figure „Connectors“	21
Table 7: Legend for Figure „Display Elements – Power Supply“	22
Table 8: Legend for Figure „Display Elements – Bus Connection“	22
Table 9: Legend for Figure “Operating Elements “	23
Table 10: Technical Data – Device	24
Table 11: Technical Data – Supply	24
Table 12: Technical Data – Connection Types: Interfaces	24
Table 13: Technical Data – Connection Types: Field Wiring.....	24
Table 14: Technical Data – Connection Types: Power Jumper Contacts	24
Table 15: Technical Data – Connection Types: Internal Data Bus	24
Table 16: Technical Data – Communication.....	25
Table 17: Technical Data – Climatic Environmental Conditions	25
Table 18: Description of Marking Example for ATEX and IEC Ex Approved I/O Modules According to CENELEC and IEC	35
Table 19: Description of Marking Example for Ex i and IEC Ex i Approved I/O Modules According to CENELEC and IEC	37
Table 20: Description of Marking Example for I/O Modules According to NEC 500.....	38
Table 21: VDE Installation Regulations in Germany	39
Table 22: Installation Regulations in USA and Canada.....	39

WE! INNOVATE!

WAGO Kontakttechnik GmbH & Co. KG
Postfach 2880 • D-32385 Minden
Hansastraße 27 • D-32423 Minden
Phone: 05 71/8 87 – 0
Fax: 05 71/8 87 – 1 69
E-Mail: info@wago.com
Internet: <http://www.wago.com>

