

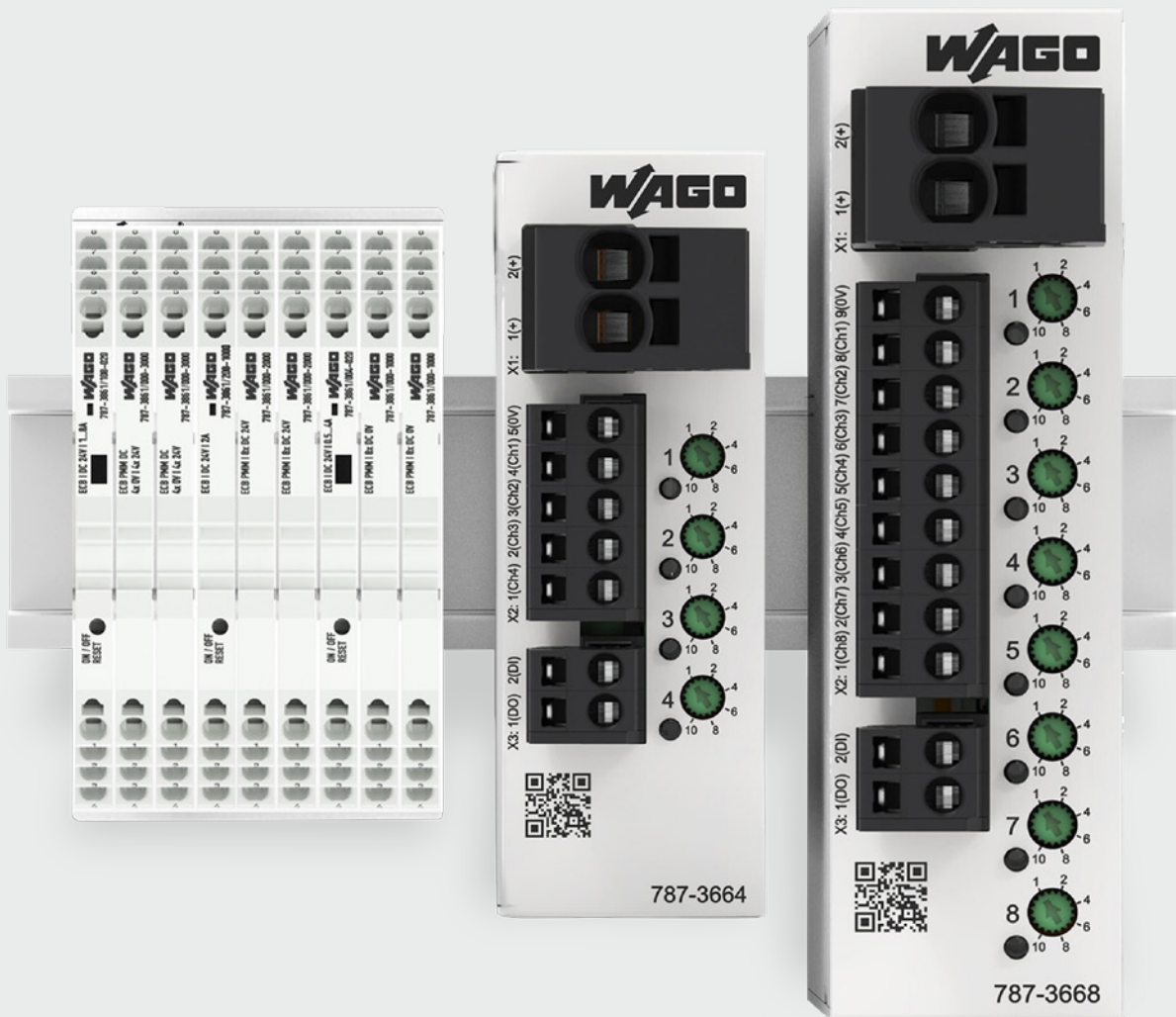

# WAGO – Electronic Circuit Breakers (ECBs)

Precise, Compact ECBs for DC Circuits



# Why Secondary-Side Fuse Protection?

On the secondary side, switched-mode power supplies provide DC voltage to control circuit loads, such as controllers, operating panels, displays, and auxiliary relays. These control circuits need wiring protection and may also require device protection if the load has no protective unit of its own. Furthermore, the Machinery Directive EN 60204-1 requires that hazardous ground faults in control circuits be detected and switched off within five seconds.

The overcurrent protection in primary switched-mode power supplies reacts very quickly to overcurrents on the output side. However, selective protection of individual current paths in the secondary circuit via fuses or conventional circuit breakers is often ineffective if the power supply cannot provide sufficiently high overcurrent, or if sufficiently high current cannot flow due to impedance.

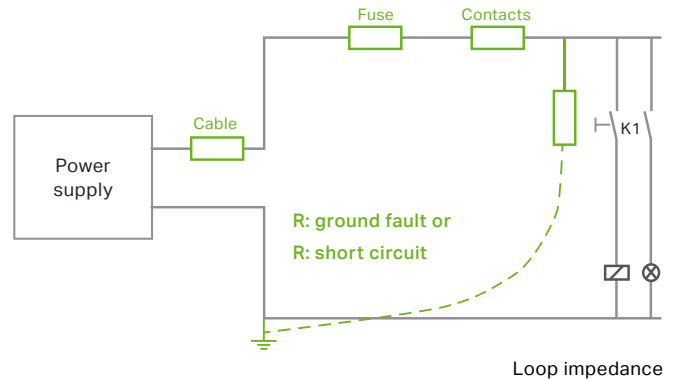

# What Types of Fuse Protection Are There?

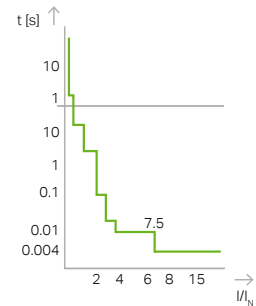
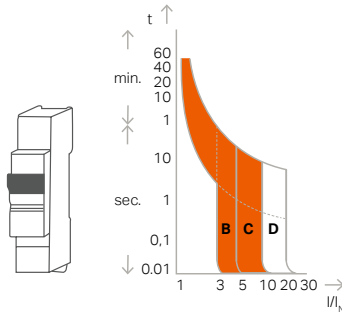
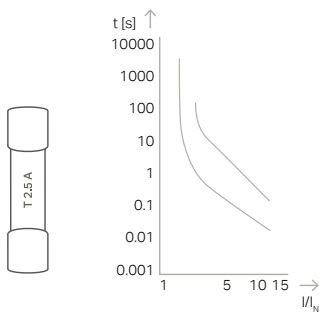

## Thermal

- Found in NH and DP fuses, for example
- High overcurrents required for fast tripping
- In the example: 10-fold overcurrent (based on the nominal value of the fuse)
- Tripping within the 30 ms (best case) or 200 ms (worst case) range
- Only two-fold overcurrent: tripping within the 2 s (best case) or >100 s (worst case) range

## Thermal and Magnetic

- Found in circuit breakers or motor protection switches
- High overcurrents required for fast tripping
- In the example: three-fold to five-fold overcurrent for B-characteristic and AC operation; additional DC safety factor of 1.2 or 1.5
- Thus, in the worst-case scenario, a tripping current 7.5 times the nominal current is necessary

## Electronic

- Precision setting options
- Responds within a short time, even with low overcurrents
- Can protect long cable runs and small cross-sections

NH fuse = low-voltage high-power fuse

DP fuse = miniature device protection fuse

# How Does an ECB Work?

An ECB monitors whether the output current is greater than the nominal current. As soon as the output current exceeds the nominal current and the current analysis indicates a short circuit rather than a switch-on process, the output is switched off electronically by a semiconductor switch. The tripping time depends on the magnitude of the overcurrent.

The measurement of the output current, the processing and calculation of the tripping time, and the actuation of the semiconductor switch are performed by a microprocessor that monitors one or more output channels. Examples of the corresponding tripping times can be found in the figure on the right.

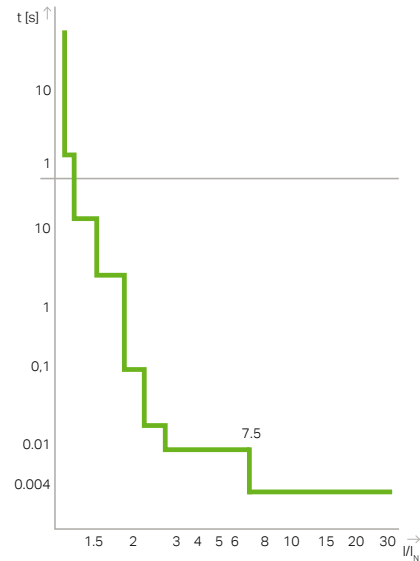

## Advantages of ECBs

- Can switch off secondary-side overcurrents and short circuits – even for long cable runs and small conductor cross-sections – with precision, speed and repeatability
- Remote functionality via digital inputs and outputs
- Integrated load management effectively reduces the current flow during the switch-on process. The following functions are executed based on the connected loads: First, capacitive loads are detected and initially preloaded by pulses. Additionally, the individual channels are switched on with a time delay according to the load of the individual channels. These steps minimize the pulse (peak) resulting from the switch-on process. This reduction of the inrush current actively reduces the burden on the power supply system
- Readout options (communication) through serial data transmission via

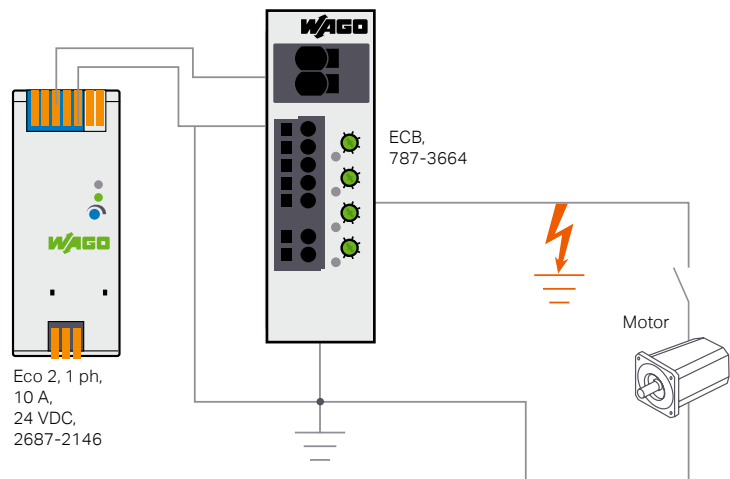

- digital input and output or IO-Link, Manchester protocol or Modbus RTU
- Compact size/width, e.g., eight output channels in just 32 mm
- The nominal current can be set for each channel

- Meets EN 60204-1 requirements for dependable switch-off of ground faults within five seconds

# WAGO ECBs

Precise, Compact ECBs for DC Circuits



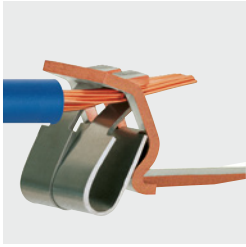

### Push-in CAGE CLAMP® Connection

- Push-in CAGE CLAMP® connection for tool-free termination of solid and stranded conductors with ferrules

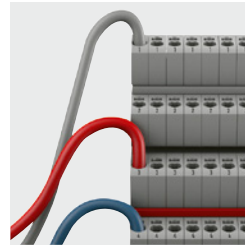

### Easy Wiring

- Input potential up to 40 A via double connection
- Signal output can be commoned for up to 30 devices
- Total reset by commoning the signal inputs

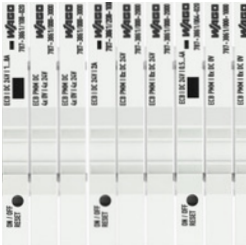

### Intuitive Status Indication

- Integrated multi-color LEDs (green/yellow/red) indicate the operating status of each channel
- An operating button for ON/OFF, RESET and ECB configuration

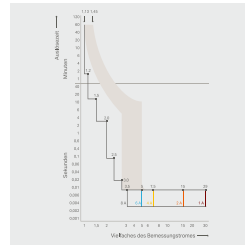

### Trip Characteristics

- Reliable, fast, precise disconnection in case of overcurrent or short circuit
- High switch-on capacities >50,000  $\mu$ F (for NEC Class 2 versions: >7,000  $\mu$ F)



### The Industry's Most Compact

- "True" 6.0 mm width maximizes panel space

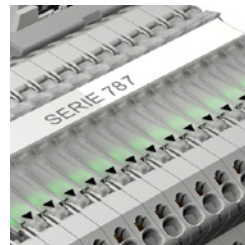

### Marking

- Device labeling with WMB Markers or WAGO TOPJOB® S Marking Strips



### Versatile Configuration Options

- Optional nominal current setting 1 ... 4 A in 0.5 A increments or 1 ... 8 A in 1 A increments
- Comprehensive configuration options for the digital signal output





### Intuitive Status Indication

- Backlit buttons for each output channel
- For switch-on/switch-off and acknowledgment
- Integrated, multi-color LEDs indicate the operating status of each channel



### Communication 1.0

- Remote digital input DI for switching and resetting all tripped channels
- Digital output DO as a group message indicating whether one of the channels was tripped by an overcurrent

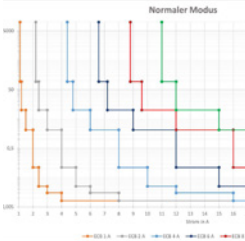

### Trip Characteristics

- Reliable, precise disconnection in case of overcurrent or short circuit
- Nominal currents can be set separately for each channel in 1 A, 2 A, 4 A, 6 A and 10 A increments
- Parallel connection of channels for higher nominal currents of 11, 12, 14 and 16 A

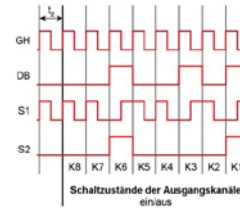

### Communication 2.0

- Remote digital input MDI (S1) for switching specific channels on and off via pulse sequence (Manchester protocol)
- Digital output MDO (S2) for transmitting the current status (on/off/tripped/overcurrent) of each individual channel
- Optional transmission of input voltage and output/nominal current value for each channel



### Rotary Switch

- Nominal current for each channel can be adjusted individually from 1 to 16 A
- The setting is visible even when no voltage is applied
- Switchable electronic key lock protects against incorrect operation

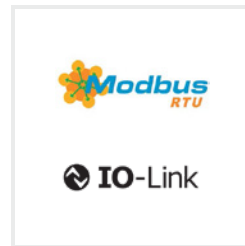

### Communication 3.0

- Modbus RTU or IO-Link interface
- Readout of status, nominal current setting, current voltage values and current values for each channel
- Setting the nominal current, as well as switch-on/off and reset of individual channels

# Communications

## ECBs

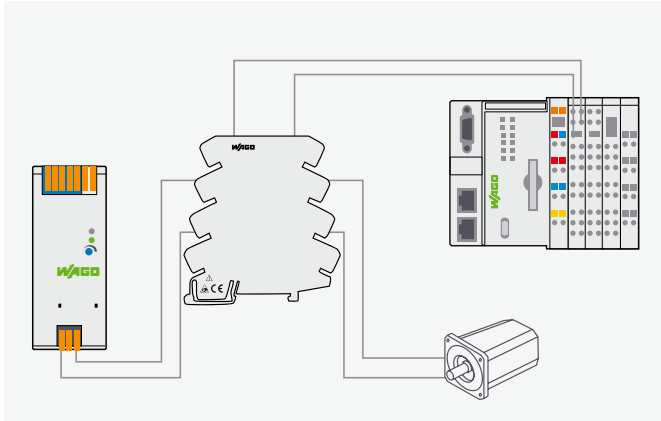

### Communication 1.0

#### Digital Signaling

ECBs can be reset remotely via a digital control signal (S1/DI). The devices can also be switched on and off via S1/DI.

The digital output signal (S2/DO) reports the status of the channel or the sum of the channels.

This output signal can be configured individually and can provide information about the DC OK contact, or even a warning threshold (70%, 80%, or 90%), for example.

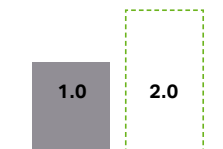

### Communication 2.0

For each channel, both its status and its voltage and current values can be transmitted individually via the integrated communication interfaces. In addition to control, it is also possible to set the nominal currents and make other settings. A position on the rotary wheels is provided specifically for configuration access via the communication; this also makes it possible to block manual interventions from the outside on the software side later.

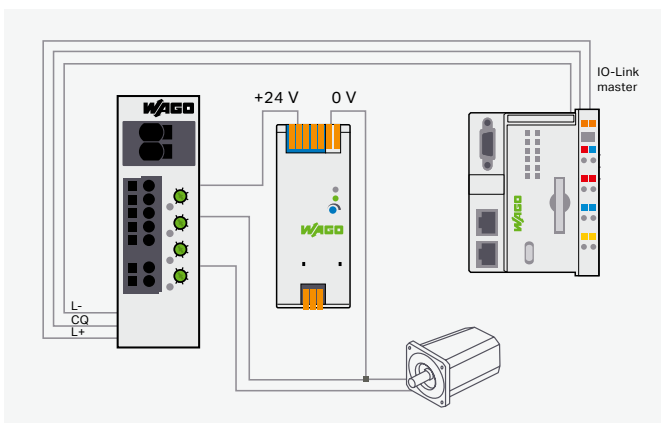

#### Manchester Protocol

The PLC communicates with the circuit breaker via a coded pulse pattern using one digital input and one digital output. This allows queries and commands to be transmitted and processed. In parallel with this, the current status of all output channels is sent via an additional signal output as a group message. This allows direct signaling in the event of status changes, in addition to the query via the protocol.

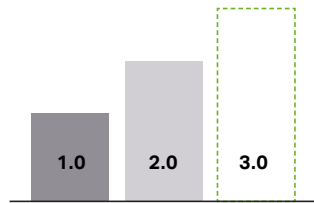

### Communication 3.0

Through an IO-Link interface implemented in COM3, the status and voltage/current values of each channel can be transmitted individually, in addition to configuring and setting the nominal currents.

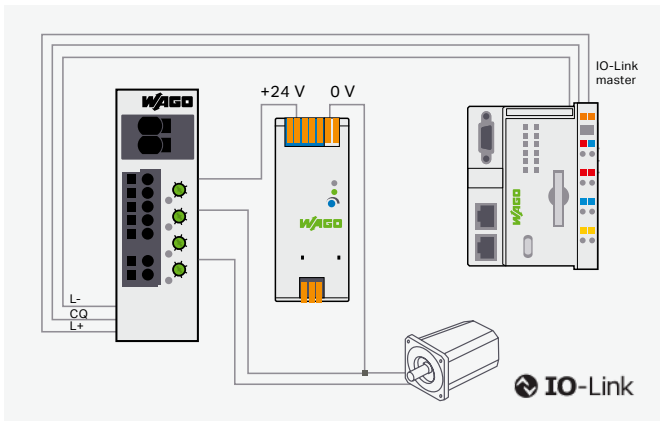

### IO-Link

Besides simple port-based initialization, IO-Link offers significantly faster, cyclical communication and requires no additional digital signaling.

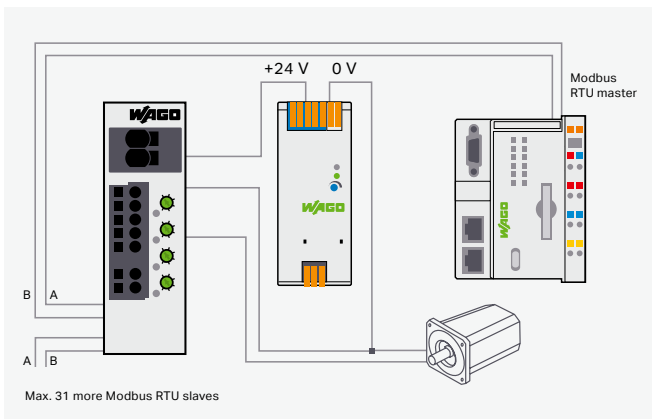

### Modbus RTU

The Modbus RTU interface offers a standardized communication protocol that enables easy integration into existing systems and guarantees reliable cyclic data transmission. ECBs can be combined in sequence by daisy-chaining the communication from device to device and using integrated switchable end resistors.

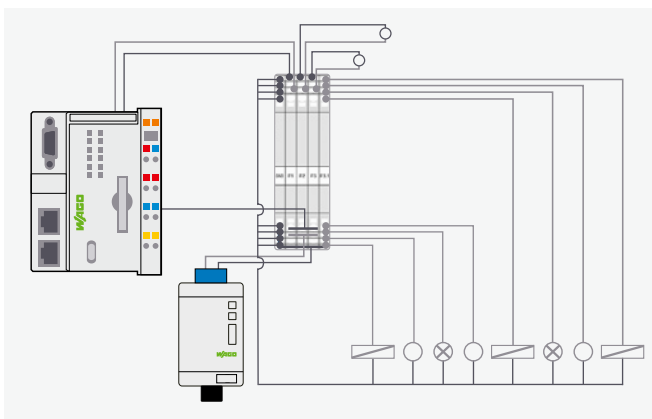

### Potential Distribution Modules

- Item Number 787-3861/000-3000 (4 × GND / 4 × 24 VDC)
- Item Number 787-3861/000-2000 (8 × 24 VDC)
- Item Number 787-3861/000-1000 (8 × GND)

Our single-channel ECB (Item Number 787-3861/X) comes standard with 2 × Vout and 1 × GND potential on the output. For optimal distribution of this potential, we recommend using the associated potential distribution modules from our portfolio. These modules fit seamlessly with the contours of our ECBs and offer an easy way to distribute the potential. By using them, you not only save time and effort during wiring but also reduce the number of rail-mount terminal blocks required.

# WAGO ECBs

## Product Overview – ECBs

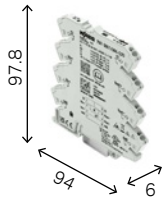

1 Channel

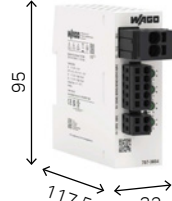

4 Channels

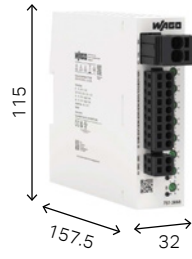

8 Channels

Nominal Voltage [V] DC	Number of Channels	Adjustable Nominal Current	Communications	Other Information	Item Number	
24	1	0.5 A	Digital input and output	NEC class 2	787-3861/050-1000	
		1 A	Digital input and output	NEC class 2	787-3861/100-1000	
		2 A	Digital input and output	NEC class 2	787-3861/200-1000	
		4 A	Digital input and output	NEC class 2	787-3861/400-1000	
		0.5 ... 4 A	Digital input and output	NEC class 2	787-3861/004-1020	
		0.5 A	Digital input and output	/	787-3861/050-0000	
		1 A	Digital input and output	/	787-3861/100-0000	
		2 A	Digital input and output	/	787-3861/200-0000	
		4 A	Digital input and output	/	787-3861/400-0000	
		0.5 ... 4 A	Digital input and output	/	787-3861/004-0020	
		6 A	Digital input and output	/	787-3861/600-0000	
		8 A	Digital input and output	/	787-3861/800-0000	
		1 ... 8 A	Digital input and output	/	787-3861/108-0020	
		/			Potential distribution module (0 V / 24 V)	787-3861/000-1000
		/			Potential distribution module (24 V)	787-3861/000-2000
/			Potential distribution module (0 V)	787-3861/000-3000		
24	4	1 ... 16 A	Digital input and output	Parallel operation and key lock	787-3664	
		1 ... 16 A	Manchester Protocol	Parallel operation and key lock	2596-3664/0000-0050	
		1 ... 16 A	IO-Link	Parallel operation and key lock	2596-3664/0000-0080	
		1 ... 16 A	Modbus RTU	Parallel operation and key lock	2596-3664/0000-0060	
24	8	1 ... 16 A	Digital input and output	Parallel operation and key lock	787-3668	
		1 ... 16 A	Manchester Protocol	Parallel operation and key lock	2596-3668/0000-0050	
		1 ... 16 A	IO-Link	Parallel operation and key lock	2596-3668/0000-0080	
		1 ... 16 A	Modbus RTU	Parallel operation and key lock	2596-3668/0000-0060	

**WAGO GmbH & Co. KG**

Postfach 2880 · D-32385 Minden  
Hansastraße 27 · D-32423 Minden

**info@wago.com**  
**www.wago.com**

Headquarters	+49 (0)571/887 - 0
Sales	+49 (0)571/887 - 44 222
Orders	+49 (0)571/887 - 44 333

WAGO is a registered trademark of WAGO Verwaltungsgesellschaft mbH.

“Copyright – WAGO GmbH & Co. KG – All rights reserved. The content and structure of the WAGO websites, catalogs, videos and other WAGO media are subject to copyright. Distribution or modification of the contents of these pages and videos is prohibited. Furthermore, the content may not be copied or made available to third parties for commercial purposes. Also subject to copyright are the images and videos that were made available to WAGO GmbH & Co. KG by third parties.”